



IS160 Rev.04 14/11/2017

# EDGE1

## centrale di comando per cancelli battenti

Istruzioni originali

**ROGER**  
BRUSHLESS



- IT - Istruzioni ed avvertenze per l'installatore - pag. 14
- EN - Instructions and warnings for the installer - pag. 43
- DE - Anweisungen und Hinweise für den Installateur - S. 72
- FR - Instructions et consignes pour l'installateur - p. 101
- ES - Instrucciones y advertencias para el instalador - pág. 130
- PT - Instruções e advertências para o instalador - pág. 159
- NLD - Aanwijzingen en waarschuwingen voor de installateur - pag. 188
- PL - Instrukcja i ostrzeżenia dla instalatora - pag. 217

 **ROGER**  
TECHNOLOGY



**IT**

### Aggiornamenti versione P3.05

1. Aggiunte nuove selezioni motore al parametro *R I* per la gestione dei motori BE20/HS, SMARTY5R e SMARTY4HS e BH23/HS
2. Aggiunto:                    parametro *22* - Abilitazione gestione apertura con esclusione della richiusura automatica;  
                                     parametro *5B* - Selezione del tipo di test fotocellule sull'ingresso FT1;  
                                     parametro *59* - Selezione del tipo di test fotocellule sull'ingresso FT2;
3. Aggiunta gestione del comando *RP* : l'attivazione persistente del comando di apertura inibisce la richiusura automatica.

**EN**

### Updates of version P3.05

1. New motor options have been added for parameter *R I* to manage BE20/HS, SMARTY5R and SMARTY4HS and BH23/HS.
2. Parameter added:        parameter *22* - Enabling of management for opening with automatic reclosure exclusion;  
                                     parameter *5B* - Selecting the type of photocell test on input FT1;  
                                     parameter *59* - Selecting the type of photocell test on input FT2;
3. Management of the *RP* maintained command added (inhibits automatic reclosure).

**DE**

### Aktualisierungen Version P3.05

1. Hinzufügen neuer Motorauswahl zum Parameter *R I* BE20/HS, SMARTY5R und SMARTY4HS und BH23/HS zu Verwaltung.
2. Hinzugefügter:            Parameter *22* - Aktivierung der Öffnungsverwaltung mit Deaktivierung der automatischen erneuten Schließung;  
                                     Parameter *5B* - Auswahl des Fotozellen-Testtyps am Eingang FT1;  
                                     Parameter *59* - Auswahl des Fotozellen-Testtyps am Eingang FT2;
3. Hinzugefügte Verwaltung des gehaltenen Befehls *RP* (verhindert die automatische erneute Schließung).

**FR**

### Mises à jour version P3.05

1. Ajout de nouvelles sélections moteur au paramètre *R I* pour la gestion de BE20/HS, SMARTY5R et SMARTY4HS et BH23/HS
2. Ajout:                        paramètre *22* - Activation gestion ouverture avec exclusion de la fermeture automatique;  
                                     paramètre *5B* - Sélection du type d'essai phocellules sur l'entrée FT1;  
                                     paramètre *59* - Sélection du type d'essai phocellules sur l'entrée FT2;
3. Ajout gestion de la commande *RP* maintenue (empêche la fermeture automatique).

**ES**

### Actualización de la versión P3.05

1. Se han añadido nuevas selecciones del motor al parámetro *R I* pour la gestion de BE20/HS, SMARTY5R y SMARTY4HS y BH23/HS
2. Añadido:                    parámetro *22* - Habilitación gestión apertura con exclusión del cierre automática;  
                                     parámetro *5B* - Selezione del tipo di test fotocellule sull'ingresso FT1;  
                                     parámetro *59* - Selezione del tipo di test fotocellule sull'ingresso FT2;
3. Añadido la gestión del mando *RP* mantenido (inhibe el cierre automático).

**PT**

### Atualizações da versão P3.05

1. Adição de novas seleções de motor ao parâmetro *R I* para a gestão de BE20/HS, SMARTY5R e SMARTY4HS e BH23/HS
2. Adição:                    parâmetro *22* - Ativação da gestão de abertura com exclusão do fecho automático  
                                     parâmetro *5B* - Seleção do tipo de teste de fotocélulas na entrada FT1;  
                                     parâmetro *59* - Seleção do tipo de teste de fotocélulas na entrada FT2;
3. Inclusão da gestão do comando *RP* mantido (inibe o fecho automático).

**NL**

### Update versie P3.05

1. Toevoegingen nieuwe selecties motor voor parameter *R I* . Voor het beheer BE20/HS, SMARTY5R of SMARTY4HS of BH23/HS
2. Toevoeging:                parameter *22* - Activering beheer opening met uitsluiting van de automatische hersluiting;  
                                     parameter *5B* - Selectie van het type van test van de fotocellen op de ingang FT1;  
                                     parameter *59* - Selectie van het type van test van de fotocellen op de ingang FT2;
3. Toevoeging beheer van dodemansbediening *RP* (belet de automatische hersluiting).

**PL**

### Aktualizacja wersji P3.05

1. Dodanie nowych opcji silnika do parametru *R I* . Do zarządzania BE20/HS, SMARTY5R, SMARTY4HS lub BH23/HS
2. Dodawanie:                parametru *22* - Aktywacja zarządzania otwieraniem z wyłączaniem ponownego zamykania automatycznego;  
                                     parametru *5B* - Wybór typu testu fotokomórek na wejściu FT1;  
                                     parametru *59* - Wybór typu testu fotokomórek na wejściu FT2;
3. Dodawanie zarządzania poleceniem *RP* przytrzymywanym (blokuje ponowne zamykanie automatyczne).

<b>IT</b>	1	Avvertenze generali	14
	2	Descrizione prodotto	14
	3	Aggiornamenti versione P3.05	14
	4	Caratteristiche tecniche prodotto	15
	5	Descrizione dei collegamenti	15
	5.1	Collegamenti elettrici	16
	6	Tasti funzione e display	17
	7	Accensione o messa in servizio	17
	8	Modalità funzionamento display	18
	8.1	Modalità visualizzazione dei parametri	18
	8.2	Modalità visualizzazione di stato comandi e sicurezze	18
	8.3	Modalità TEST	18
	8.4	Modalità Stand By	19
	9	Apprendimento della corsa	20
	9.1	Prima di procedere	20
	9.2	Procedura di apprendimento	21
	10	Indice dei parametri	22
	11	Menù parametri	24
	12	Comandi e accessori	35
	13	Segnalazione degli ingressi di sicurezza e dei comandi (modalità TEST)	37
	14	Segnalazione allarmi e anomalie	38
	15	Modalità INFO	40
	16	Sblocco meccanico	41
	17	Modalità di recupero posizione SENZA encoder assoluto	41
	18	Modalità di recupero posizione CON encoder assoluto (solo serie SMARTY)	41
	19	Collaudo	41
	20	Manutenzione	42
	21	Smaltimento	42
	22	Informazioni aggiuntive e contatti	42
	23	Dichiarazione di Conformità	42

<b>DE</b>	1	Allgemeine Sicherheitshinweise	72
	2	Produktbeschreibung	72
	3	Aktualisierungen Version P3.05	72
	4	Technische Daten des Produkts	73
	5	Beschreibung der Anschlüsse	73
	5.1	Elektrische Anschlüsse	74
	6	Funktionstasten und Display	75
	7	Einschalten oder Inbetriebnahme	75
	8	Funktion Display	76
	8.1	Parameter-Anzeigemodus	76
	8.2	Anzeige des Status von Befehlen und Sicherheitseinrichtungen	76
	8.3	TEST-Modus	76
	8.4	Standby-Modus	77
	9	Lernlauf	78
	9.1	Zunächst	78
	9.2	Einlernverfahren	79
	10	Index der Parameter	80
	11	Menü Parameter	82
	12	Befehle und Zubehör	93
	13	Meldung der Sicherheitseingänge und der Befehle (TEST-Modus)	95
	14	Meldung von Alarmen und Störungen	96
	15	Diagnostik - Betriebsart Info	98
	16	Mechanische Entriegelung	99
	17	Vorgangsweise zur Positionskorrektur OHNE Absolut-Encoder	99
	18	Vorgangsweise zur Positionskorrektur MIT Absolut-Encoder (nur Serie SMARTY)	99
	19	Abnahmeprüfung	99
	20	Wartungsarbeiten	100
	21	Entsorgung	100
	22	Zusätzliche Informationen und Kontakte	100
	23	Konformitätserklärung	100

<b>EN</b>	1	General safety precautions	43
	2	Product description	43
	3	Updates of version P3.05	43
	4	Technical characteristics of product	44
	5	Description of connections	44
	5.1	Electrical connections	45
	6	Function buttons and display	46
	7	Switching on or commissioning	46
	8	Display function modes	47
	8.1	Parameter display mode	47
	8.2	Command and safety device status display mode	47
	8.3	TEST mode	47
	8.4	Standby mode	48
	9	Travel acquisition	49
	9.1	Before starting	49
	9.2	Acquisition procedure:	50
	10	Index of parameters	51
	11	Parameters menu	53
	12	Commands and Accessories	64
	13	Safety input and command status (TEST mode)	66
	14	Alarms and faults	67
	15	Procedural verifications - INFO Mode	69
	16	Mechanical release	70
	17	Position recovery WITHOUT the absolute encoder	70
	18	Position recovery WITH the absolute encoder (SMARTY range only)	70
	19	Initial testing	70
	20	Maintenance	71
	21	Disposal	71
	22	Additional information and contact details	71
	23	Declaration of Conformity	71

<b>FR</b>	1	Consignes générales de sécurité	101
	2	Description produit	101
	3	Mises à jour version P3.05	101
	4	Caractéristiques techniques produit	102
	5	Description des raccordements	102
	5.1	Branchements électriques	103
	6	Touches fonction et écran	104
	7	Allumage ou mise en service	104
	8	Modalités fonctionnement écran	105
	8.1	Modalités affichage des paramètres	105
	8.2	Modalité d'affichage d'état commandes et sécurités	105
	8.3	Modalité TEST	105
	8.4	Modalité Stand By	106
	9	Apprentissage de la course	107
	9.1	Avant de procéder	107
	10	Index des paramètres	109
	11	Menu paramètres	111
	12	Commandes et accessoires	122
	13	Signalisation des entrées de sécurité et des commandes (modalités TEST)	124
	14	Signalisations alarmes et anomalies	125
	15	Diagnostic - Modalité info	127
	16	Déblocage mécanique	128
	17	Modalités de récupération position SANS encodeur absolu	128
	18	Modalités de récupération position AVEC encodeur absolu (uniquement série SMARTY)	128
	19	Test	128
	20	Entretien	129
	21	Élimination	129
	22	Informations complémentaires et contacts	129
	23	Déclaration de conformité	129

<b>ES</b>	1	Advertencias generales	130
	2	Descripción del producto	130
	3	Actualización de la versión P3.05	130
	4	Características técnicas del producto	131
	5	Descripción de las conexiones	131
	5.1	Conexiones eléctricas	132
	6	Teclas de función y pantalla	133
	7	Encendido o puesta en servicio	133
	8	Modo de funcionamiento de la pantalla	134
	8.1	Modos de visualización de los parámetros	134
	8.2	Modos de visualización de indicaciones de seguridad y comandos	134
	8.3	Modo de TEST	134
	8.4	Modo Stand By	135
	9	Aprendizaje del recorrido	136
	9.1	Antes de actuar:	136
	9.2	Procedimiento de aprendizaje:	137
	10	Índice de los parámetros	138
	11	Menú de parámetros	140
	12	Comandos y accesorios	151
	13	Señalización de las entradas de seguridad y de los comandos (Modo TEST)	153
	14	Señalización de alarmas y anomalías	154
	15	Diagnostica - Modo Info	156
	16	Desbloqueo mecánico	157
17	Modo de recuperación de la posición SIN codificador absoluto	157	
18	Modo de recuperación de la posición CON codificador absoluto (solo serie SMARTY)	157	
19	Ensayo	157	
20	Mantenimiento	158	
21	Eliminación	158	
22	Información adicional y contactos	158	
23	Declaración de Conformidad	158	

<b>NL</b>	1	Algemene waarschuwingen	188
	2	Beschrijving product	188
	3	Update versie P3.05	188
	4	Technische kenmerken product	189
	5	Beschrijving aansluitingen	189
	5.1	Elektrische aansluitingen	190
	6	Functietoetsen en display	191
	7	Inschakeling en inbedrijfsstelling	191
	8	Bedrijfsmodus display	192
	8.1	Modus van weergave parameters	192
	8.2	Modus van weergave van de status bedieningen en veiligheden	192
	8.3	TEST modus	192
	8.4	Stand By modus	193
	9	Lering van de slag	194
	9.1	Voordat de handelingen worden uitgevoerd:	194
	9.2	Procedure van lering	195
	10	Inhoudsopgave van de parameters	196
	11	Menu parameters	198
	12	Bedieningen en accessoires	209
	13	Signalering van de veiligheidsingangen en van de bedieningen (modus TEST)	211
	14	Signalering alarmen en storingen	212
	15	Modus INFO	214
	16	Mechanische deblokking	215
17	Modus terugwinning positie ZONDER absolute encoder	215	
18	Modus terugwinning positie MET absolute encoder (enkel serie SMARTY)	215	
19	Test	215	
20	Onderhoud	216	
21	Inzameling	216	
22	Bijkomende informatie en contact	216	
23	Verklaring van Overeenstemming	216	

<b>PT</b>	1	Advertências gerais	159
	2	Descrição do produto	159
	3	Atualizações da versão P3.05	159
	4	Caraterísticas técnicas do produto	160
	5	Descrição das ligações	160
	5.1	Ligações elétricas	161
	6	Teclas de função e display	162
	7	Ignição ou comissionamento	162
	8	Modalidade de funcionamento do display	163
	8.1	Modalidade de visualização dos parâmetros	163
	8.2	Modalidade de visualização de estado dos comandos e dispositivos de segurança	163
	8.3	Modalidade TESTE	163
	8.4	Modalidade Stand By	164
	9	Aprendizagem do curso	165
	9.1	Antes de proceder	165
	9.2	Procedimento de aprendizado:	166
	10	Índice dos parâmetros	167
	11	Menu dos parâmetros	169
	12	Comandos e acessórios	180
	13	Sinalização das entradas de segurança e dos comandos (modalidade TEST)	182
	14	Sinalização de alarmes e anomalias	183
	15	Diagnosticar - Modo INFO	185
	16	Desbloqueio mecânico	186
17	Modo de recuperação de posição SEM encoder absoluto	186	
18	Modo de recuperação da posição COM encoder absoluto (apenas série SMARTY)	186	
19	Teste	186	
20	Manutenção	187	
21	Descarte	187	
22	Informações adicionais e contatos	187	
23	Declaração de conformidade	187	

<b>PL</b>	1	Ostrzeżenia ogólne	217
	2	Opis urządzenia	217
	3	Aktualizacja wersji P3.05	217
	4	Charakterystyka techniczna urządzenia	218
	5	Opis połączeń	218
	5.1	Połączenia elektryczne	219
	6	Przyciski funkcyjne i wyświetlacz	220
	7	Włączanie lub uruchamianie	220
	8	Tryby działania wyświetlacza	221
	8.1	Wyświetlanie parametrów	221
	8.2	Wyświetlanie statusu sterowniczych i zabezpieczeń	221
	8.3	Tryb TEST	221
	8.4	Tryb Stand By	222
	9	Programowanie ruchu	223
	9.1	Wcześniej	223
	9.2	Procedura programowania ruchu	224
	10	Spis parametrów	225
	11	Menu parametrów	227
	12	Elementy sterownicze i akcesoria	238
	13	Sygnalizacja wejść bezpieczeństwa i sygnałów sterowniczych (tryb TEST)	240
	14	Sygnalizacje alarmowe i błędy	241
	15	Tryb INFO	243
	16	Odblokowanie mechaniczne	244
17	Tryb szukania pozycji BEZ enkodera absolutnego	244	
18	Tryb szukania pozycji Z enkoderem absolutnym (tylko seria SMARTY)	244	
19	Testy odbiorcze	244	
20	Konserwacja	245	
21	Utylizacja	245	
22	Informacje dodatkowe i dane kontaktowe	245	
23	Deklaracja zgodności	245	



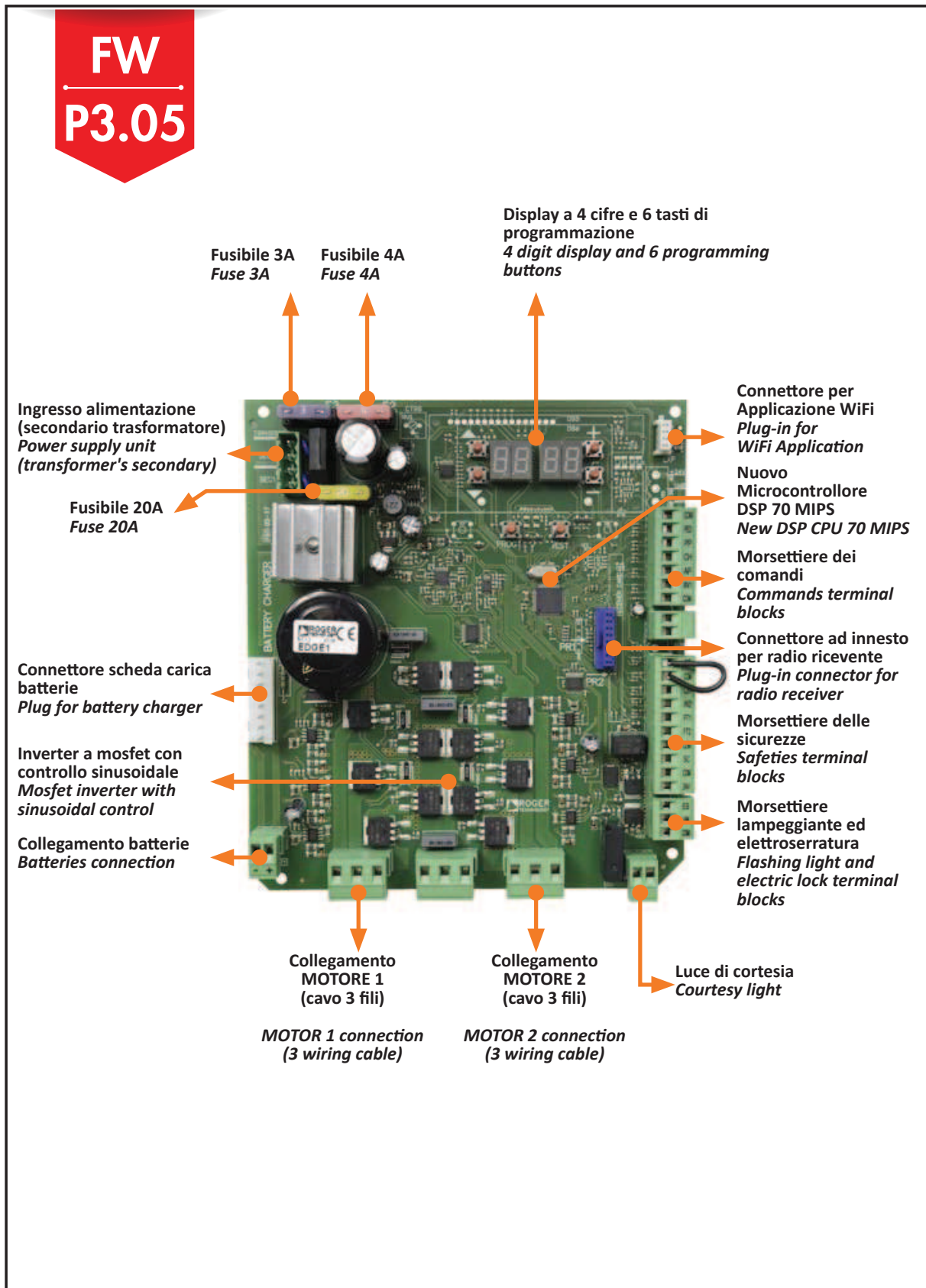

1

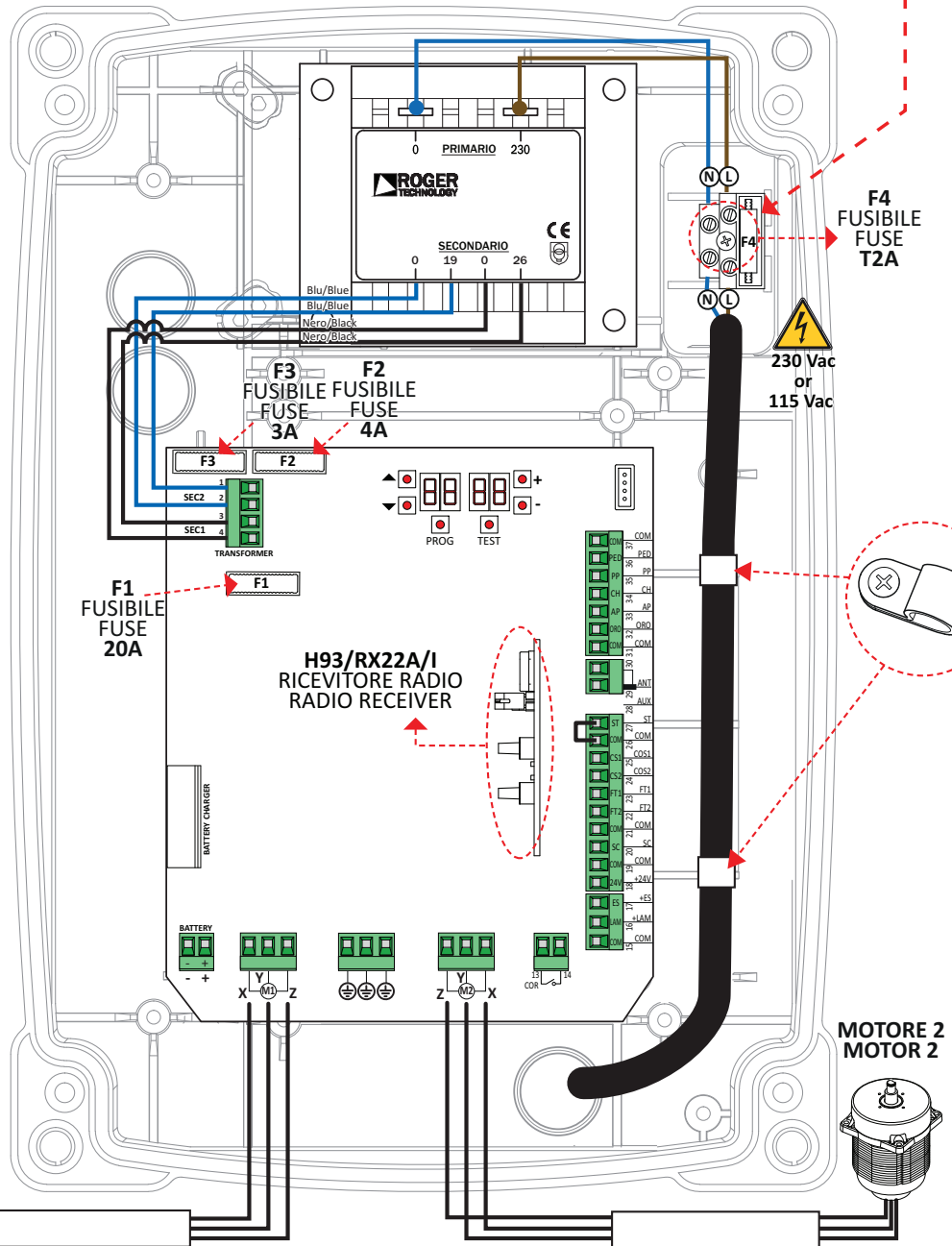
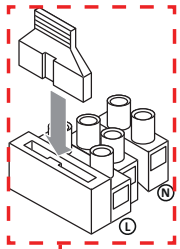

2

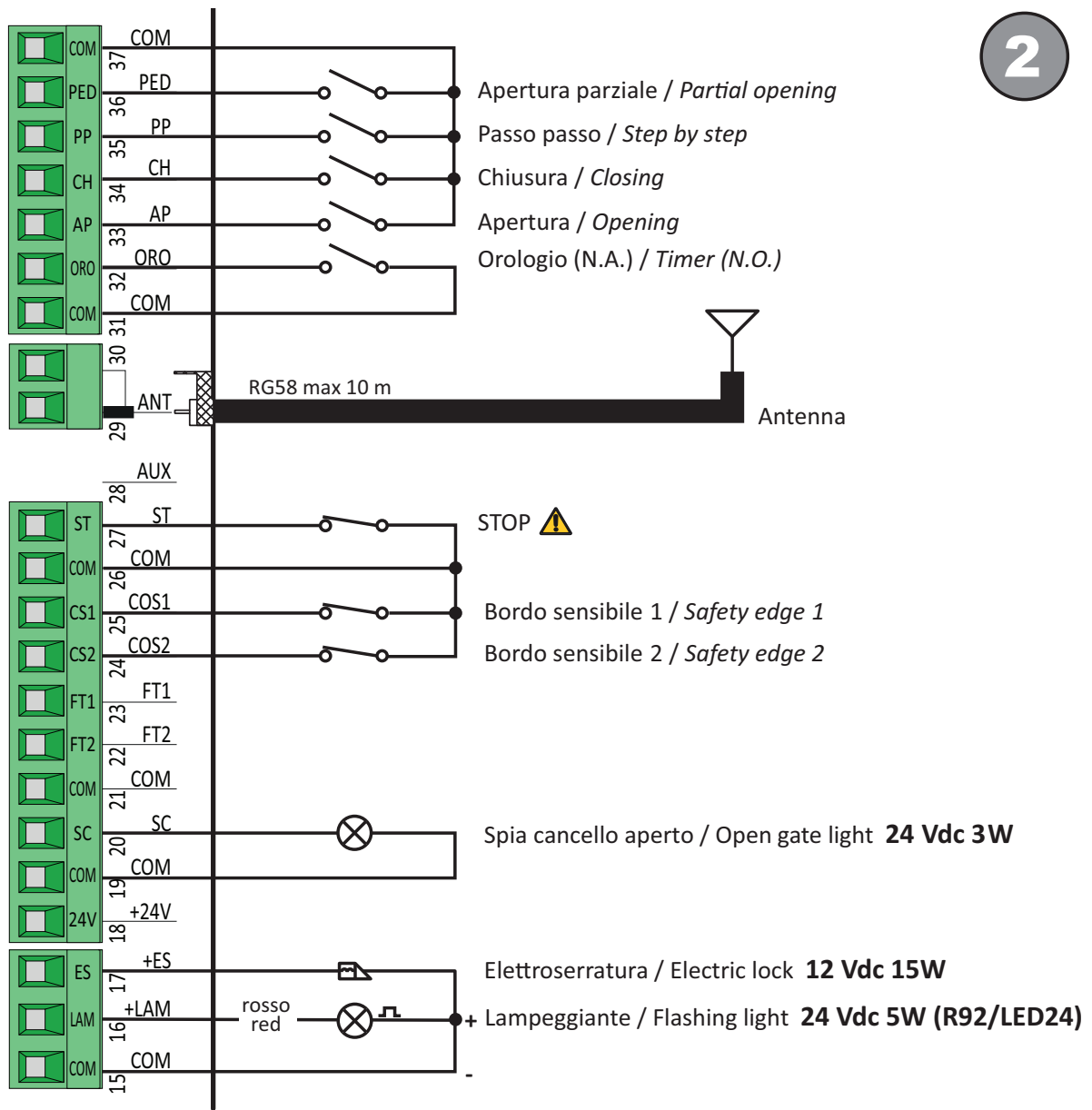

3

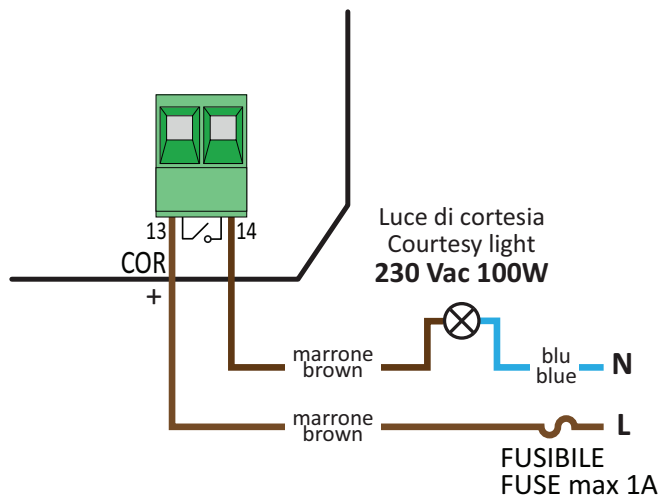



**COLLEGAMENTO CON 1 COPPIA FOTOCELLULE SINCRONIZZABILI**  
**CONNECTION WITH 1 PAIR OF SYNCHRONOUS PHOCCELLS**

4

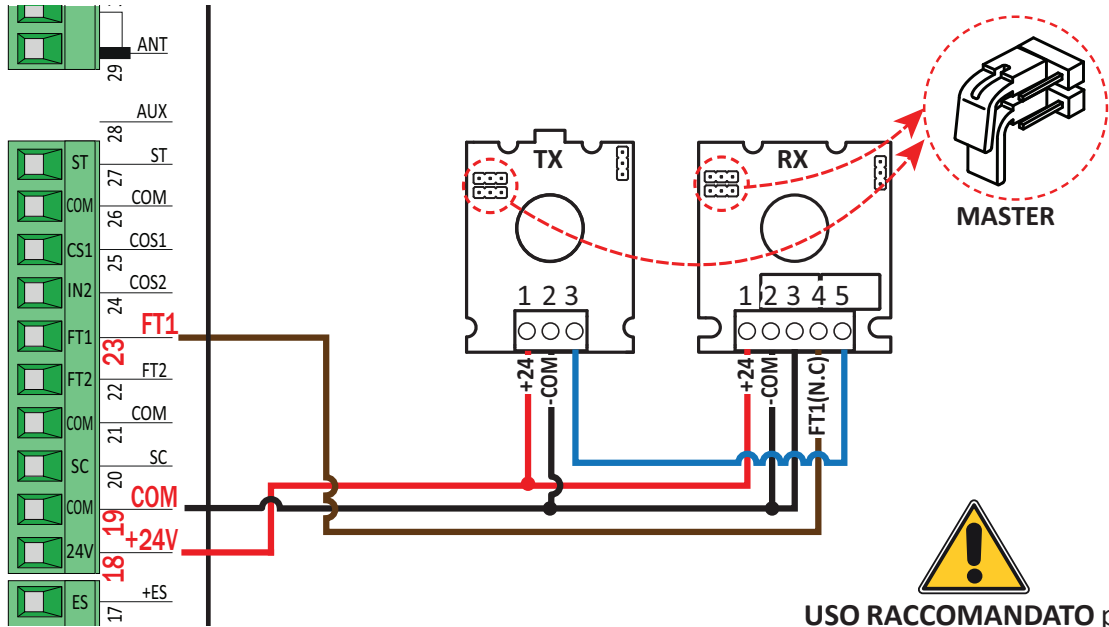

**USO RACCOMANDATO** per fotocellule Serie **F4ES - F4S**

**RECOMMENDED USE** for Series **F4ES - F4S** photocells

**COLLEGAMENTO CON 2 COPPIE FOTOCELLULE SINCRONIZZABILI**  
**CONNECTION WITH 2 PAIRS OF SYNCHRONOUS PHOCCELLS**

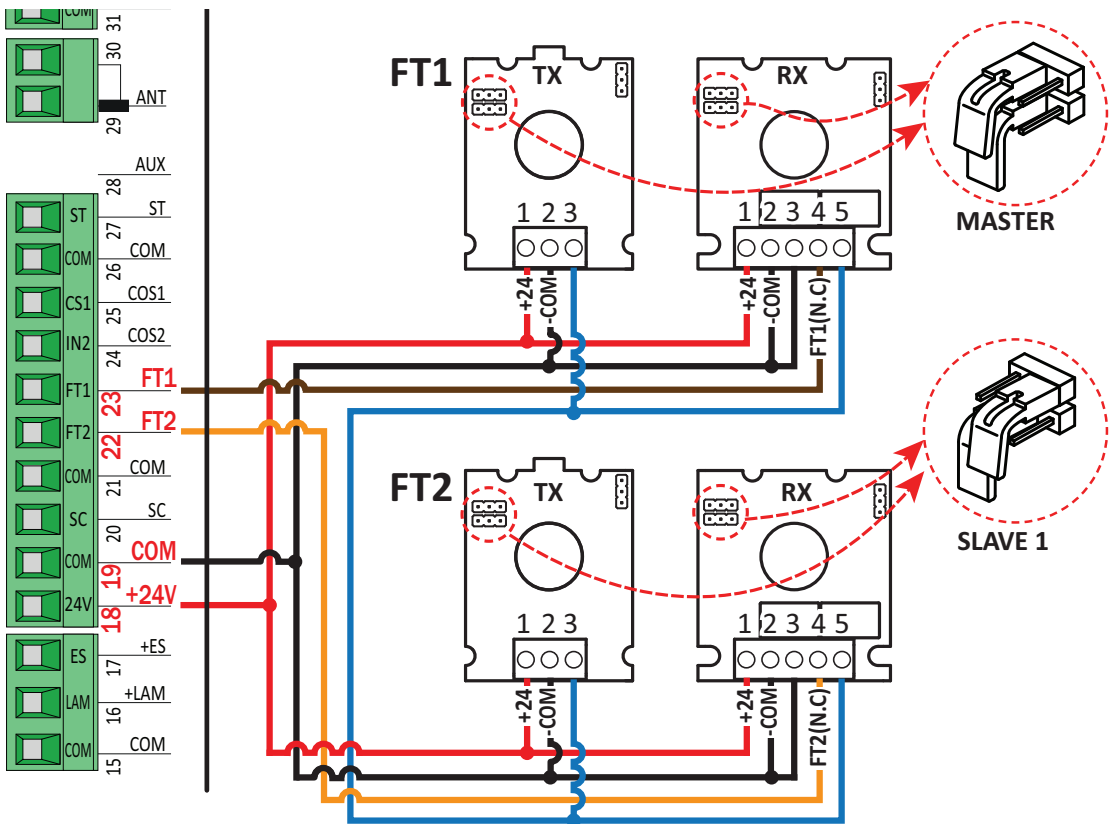

# 5

## TEST FOTOCELLULE · PHOTOCELLS TEST (impostare / set AB 02)

### COLLEGAMENTO CON 1 COPPIA FOTOCELLULE SINCRONIZZABILI CONNECTION WITH 1 PAIR OF SYNCHRONOUS PHOCELLS

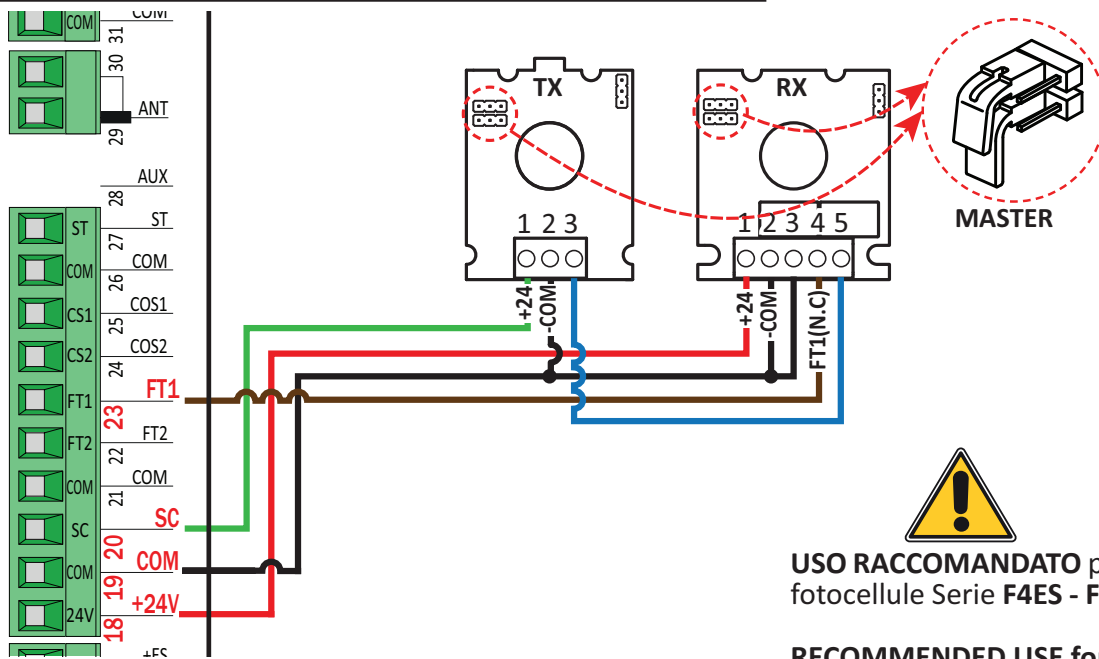

### COLLEGAMENTO CON 2 COPPIE FOTOCELLULE SINCRONIZZABILI CONNECTION WITH 2 PAIRS OF SYNCHRONOUS PHOCELLS

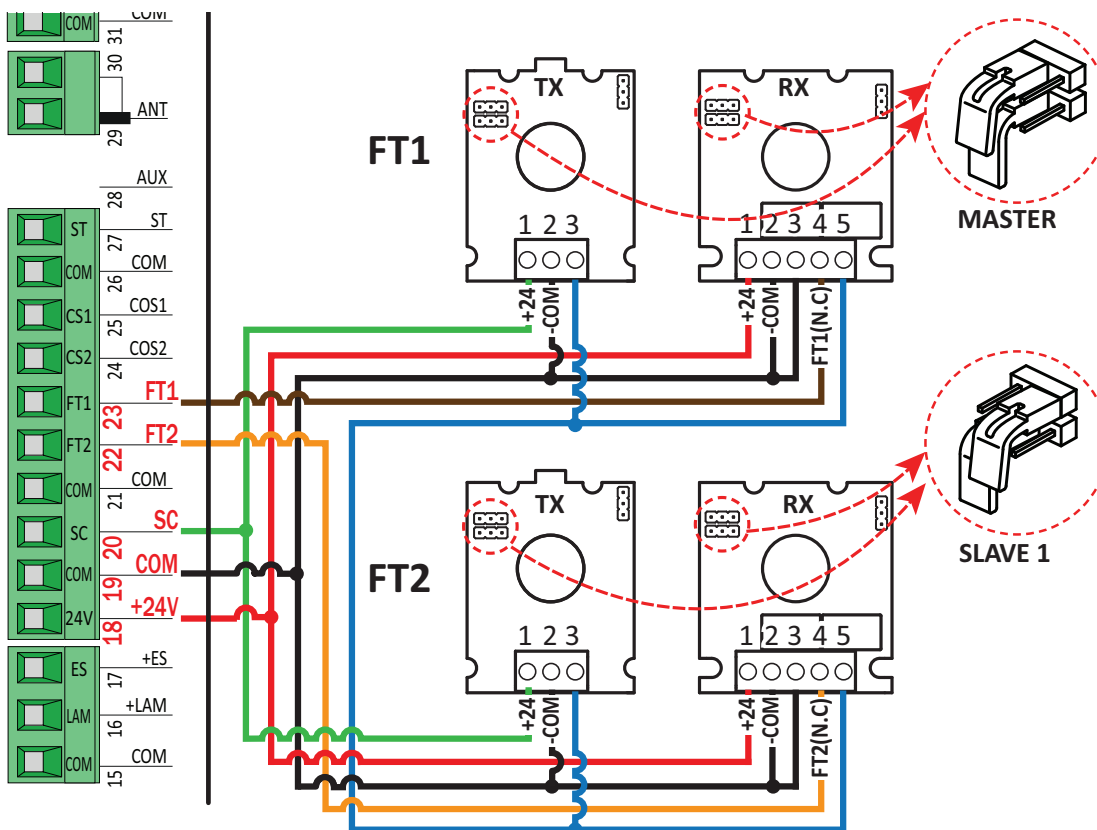

**BATTERY SAVING** (impostare · set *AB 03*)

**BATTERY SAVING + TEST FOTOCELLULE · PHOTOCELLS TEST**  
(impostare · set *AB 04*)

6

**COLLEGAMENTO CON 1 COPPIA FOTOCELLULE SINCRONIZZABILI**  
**CONNECTION WITH 1 PAIR OF SYNCHRONOUS PHOCELLS**

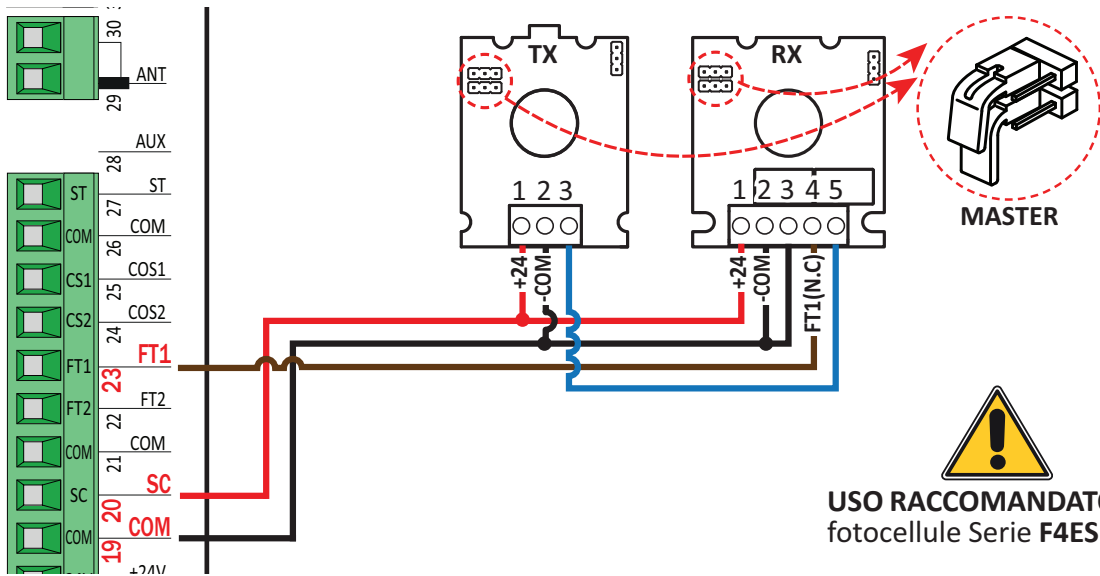

**COLLEGAMENTO CON 2 COPPIE FOTOCELLULE SINCRONIZZABILI**  
**CONNECTION WITH 2 PAIRS OF SYNCHRONOUS PHOCELLS**

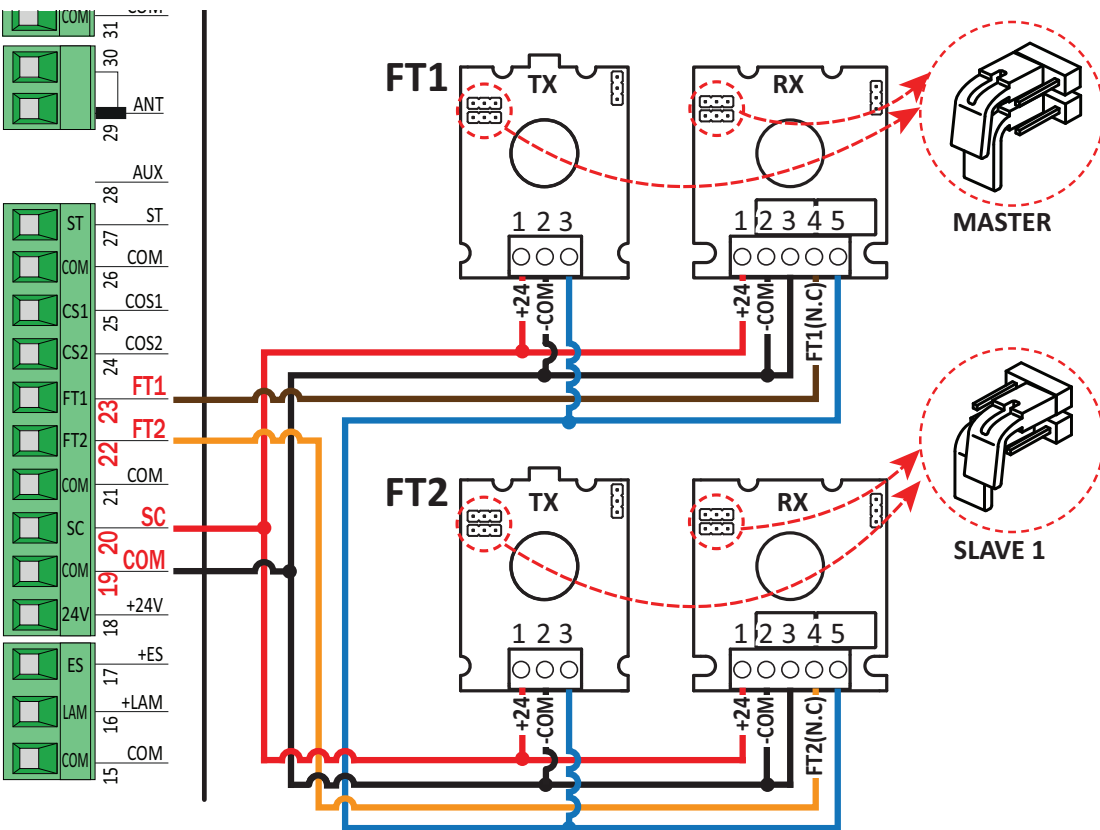

7

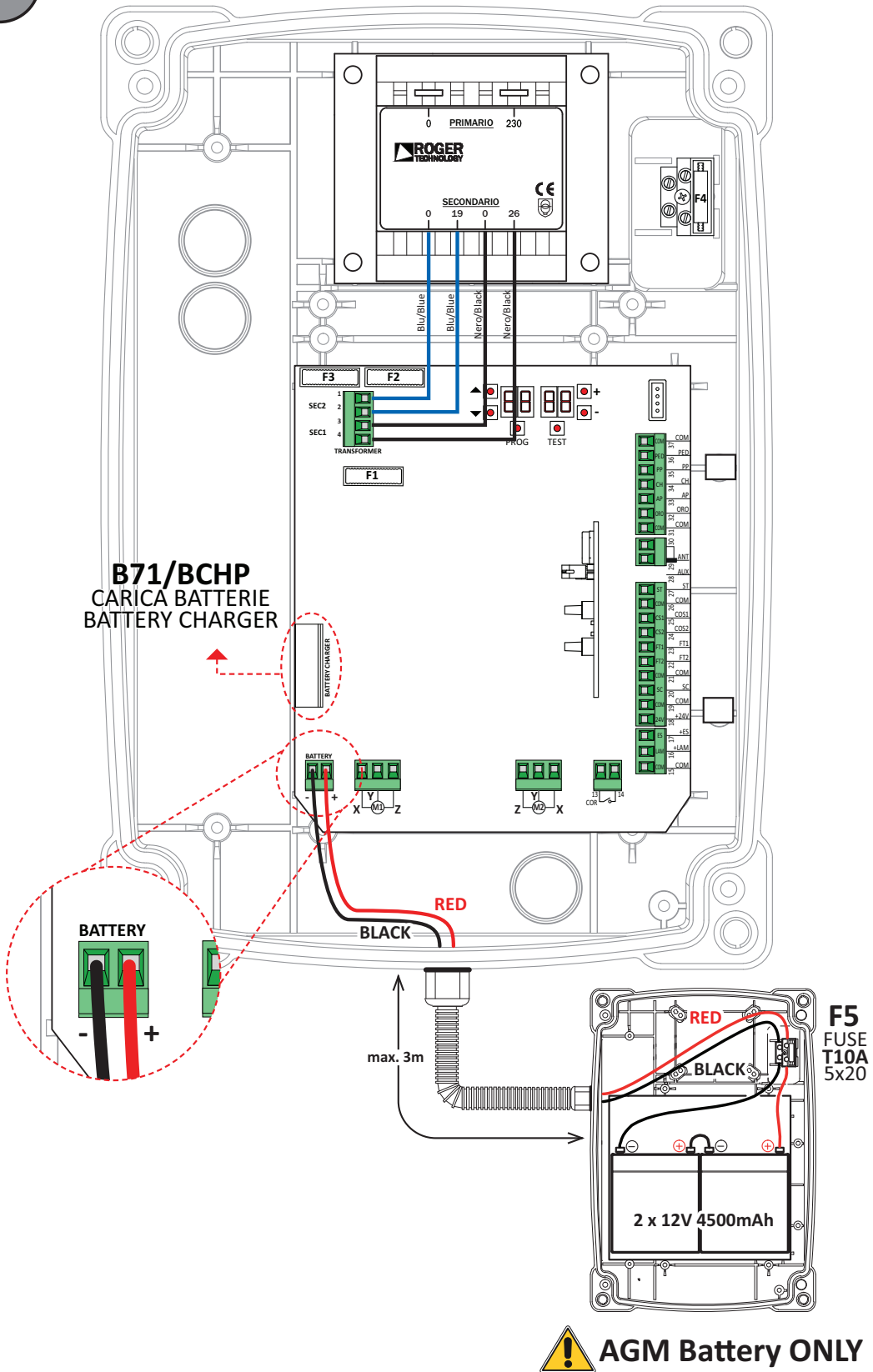

Marrone/Brown  
Blu/Blue  
Nero/Black

SMARTY/EMA

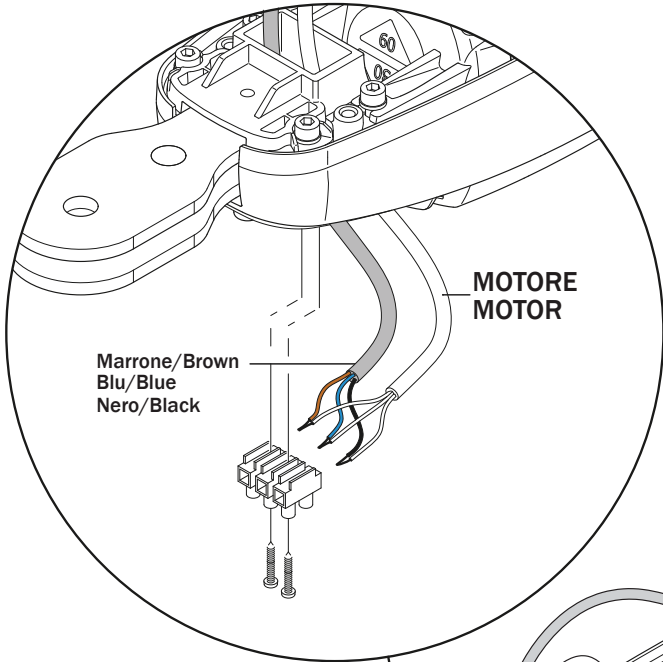
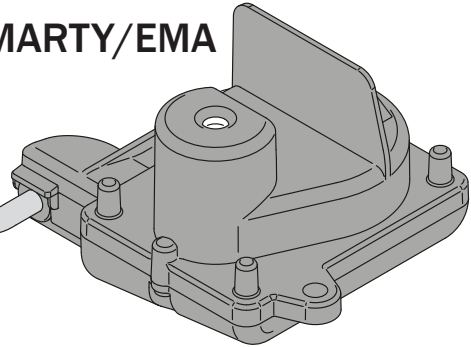

SMARTY/EMA



SMARTY

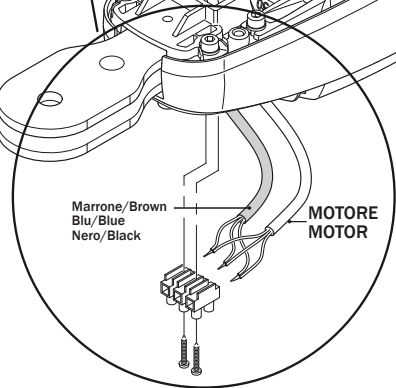

# 1 General safety precautions

---



**Warning:** incorrect installation may cause severe damage or injury.

Read the instructions carefully before installing the product.

This installation manual is intended for qualified personnel only.

ROGER TECHNOLOGY cannot be held responsible for any damage or injury due to improper use or any use other than the intended usage indicated in this manual.

Installation, electrical connections and adjustments must be performed by qualified personnel, in accordance with best practices and in compliance with applicable regulations.



Before installing the product, make sure it is in perfect condition.

A switch or an omnipolar cut-off switch with a contact opening of at least 3 mm must be installed on the mains power line.

Ensure that an adequate residual current circuit breaker and a suitable overcurrent cut-out are installed ahead of the electrical installation in accordance with best practices and in compliance with applicable legislation.

The European standards EN 12453 and EN 12445 define the minimum safety requirements for the operation of automatic doors and gates. In particular, these standards require the use of force limiting and safety devices (sensing ground plates, photocell barriers, operator detection function etc.) intended to detect persons or objects in the operating area and prevent collisions in all circumstances.

Where the safety of the installation is based on an impact force limiting system, it is necessary to verify that the characteristics and performance of the automation system are compliant with the requisites of applicable standards and legislation.

The installer is required to measure impact forces and programme the control unit with appropriate speed and torque values to ensure that the door or gate remains within the limits defined by the standards EN 12453 and EN 12445.

Ensure that an adequate residual current circuit breaker and a suitable overcurrent cut-out are installed ahead of the electrical installation in accordance with best practices and in compliance with applicable legislation.

When requested, connect the automation to an effective earthing system that complies with current safety standards.

Disconnect the mains electrical power before performing any work. Also disconnect any buffer batteries used.

Only use original spare parts when repairing or replacing products.

The packaging materials (plastic, polystyrene, etc.) should not be discarded in the environment or left within reach of children, as they are a potential source of danger.

## 2 Product description

---

The 36 V **EDGE1** control unit controls 1 or 2 ROGER brushless motors in sensorless mode for applications on large sized or heavy gate wings.

**Ensure that the parameter A1 is set correctly.** If this parameter is not set correctly, the automation system may not function properly.

**Use the same type of motor for both gate leaves in automation installations for double leaf swing gates.**

Adjust the opening and closure speed, deceleration and delay settings appropriately for the specific installation, ensuring that the gate leaves overlap correctly.

We recommend using only ROGER TECHNOLOGY accessories and control and safety devices. Specifically, we recommend installing **F4ES** or **F4S** technology photocells .

## 3 Updates of version P3.05

---





1. New motor options have been added for parameter *A1* to manage BE20/HS, SMARTY5R and SMARTY4HS and BH23/HS.
2. Parameter added: parameter *22* - Enabling of management for opening with automatic reclosure exclusion;  
parameter *5B* - Selecting the type of photocell test on input FT1;  
parameter *59* - Selecting the type of photocell test on input FT2;
3. Management of the *RP* maintained command added (inhibits automatic reclosure).



## 4 Technical characteristics of product

EN

	EDGE1/BOX	EDGE1/115/BOX
MAINS POWER VOLTAGE	230 Vac $\pm$ 10% 50 Hz	115 Vac $\pm$ 10% 60 Hz
MAXIMUM MAINS POWER ABSORPTION	600 W	
FUSES	<b>F1</b> = 20A (ATO257) motor power circuit protection. <b>F2</b> = 4A (ATO257) electric lock protection <b>F3</b> = 3A (ATO257) accessories power supply protection <b>F4</b> = T2A (5x20 mm) primary transformer coil protection	
CONNECTABLE MOTORS	2	
MOTOR POWER SUPPLY	36 Vac , with self-protected inverter	
MOTOR TYPE	sinusoidal drive brushless (ROGER BRUSHLESS)	
MOTOR CONTROL TYPE	sensorless field oriented control (FOC)	
RATED MOTOR POWER	60 W	
MAXIMUM MOTOR POWER	250 W	
MAXIMUM POWER, FLASHING LIGHT	25 W (24 Vdc)	
FLASHING LIGHT DUTY CYCLE	50%	
MAXIMUM POWER	100 W 230 Vac - 40 W 24 Vac/dc (potential free contact)	
GATE OPEN LIGHT POWER	3 W (24 Vdc)	
ELECTRIC LOCK POWER	15 W (12 Vdc)	
MAXIMUM ACCESSORY CURRENT ABSORPTION	20 W 24 Vdc (750 mA)	
OPERATING TEMPERATURE	 -20°C  +55°C	
DEGREE OF PROTECTION	IP54	
PRODUCT DIMENSION	dimensions in mm 330x230x115 Weight: 3,9 kg	



The total of the absorption values of all the accessories connected must not exceed the maximum power values shown in the table. The values are guaranteed with original ROGER TECHNOLOGY accessories ONLY. The use of non-original accessories may lead to malfunctioning. ROGER TECHNOLOGY declines all responsibility for incorrect or non-conforming installations. All the connections are protected by fuses (refer to the table). The courtesy light requires an external fuse.

## 5 Description of connections

Figure 1-2 shows connection diagrams.

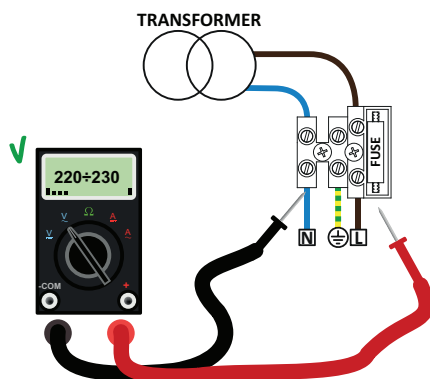

Measure the voltage on the primary mains power connection with a tester.

For the Brushless automation system to function correctly, the mains power voltage must be 230Vac (115 Vac)  $\pm$  10%.

If the voltage measured is not as indicated above or is unstable, the automation system may not work correctly.

## 5.1 Electrical connections

### CONNECTING CONTROL UNIT TO MAINS ELECTRICITY

Power supply 230 Vac  $\pm 10\%$  (115 Vac  $\pm 10\%$  EDGE1/115/BOX)

CONNECTING CONTROL PANEL TO MOTORS	L cable	
	1÷10 m	10÷30 m
Motor 1	3x2,5 mm <sup>2</sup>	3x4 mm <sup>2</sup>
Motor 2	3x2,5 mm <sup>2</sup>	3x4 mm <sup>2</sup>

### CONNECTING CONTROL PANEL TO ACCESSORIES

L cable = 1÷20 m

Photocells - Receiver	4x0,5 mm <sup>2</sup>
Photocells - Transmitter	2x0,5 mm <sup>2</sup>
Keypad H85/TDS - H85/TTD (connecting to control panel to decoder board H85/DEC-H85/DEC2)	3x0,5 mm <sup>2</sup>
Key selector R85/60	3x0,5 mm <sup>2</sup>

### CONNECTING CONTROL PANEL TO FLASHING LIGHT

Power supply 24 Vdc by LED (25 W power - Duty cycle 50%)

2x1 mm<sup>2</sup> (max 10 m)

### CONNECTING CONTROL PANEL TO ACCESSORIES

L cable

1÷20 m

Power supply 24 Vdc (3 W max)

2x0,5 mm<sup>2</sup>

### CONNECTING CONTROL PANEL TO COURTESY LIGHT

L cable

1÷20 m

Power supply 230 Vac (100 W)

2x1 mm<sup>2</sup>

### CONNECTING CONTROL PANEL TO ANTENNA

Cable type RG58

max 10 m

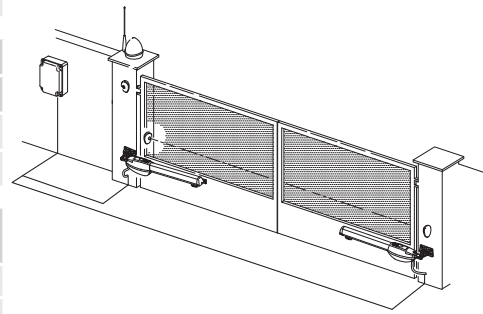

**SUGGESTIONS:** in the case of a new installation, we recommend using cables with a cross section of 3x2.5 mm<sup>2</sup> and not exceeding 10 m in

length to connect the motor with the control unit.

With existing installations, we recommend checking the cross section of the cables and that the cables themselves are in good condition.

**WARNING:** old cables or previous generation cables, especially if with a cross section of 3x1.5mm<sup>2</sup>, may impair the performance of the digital brushless motor.

**N.B.:** Using 3x1.5mm<sup>2</sup> cables is NOT recommended.

	DESCRIPTION
	Mains power supply 230 Vac $\pm 10\%$ 50 Hz connection. (EDGE1/115/BOX: 115 Vac $\pm 10\%$ 60Hz). Fuse 5x20 T2A.
	Secondary transformer input for 26 V AC motor power (SEC1) and for 19 V power to logical control and peripheral devices (SEC2). <b>N.B.:</b> Ready wired in factory by ROGER TECHNOLOGY.
<b>X-Y-Z</b> 	Connection to ROGER brushless MOTOR 1.  <b>Warning!</b> If the motor rotates in the wrong direction, simply swap any two of the three motor connectors. Check the connections illustrated in fig. 1.
<b>Z-Y-X</b> 	Connection to ROGER brushless MOTOR 2.  <b>Warning!</b> If the motor rotates in the wrong direction, simply swap any two of the three motor connectors. Check the connections illustrated in fig. 1.
<b>BATTERY</b> 	Connection to B71/BCHP (see fig. 7)  <b>i</b> See instructions for B71/BCHP for further information.

## 6 Function buttons and display

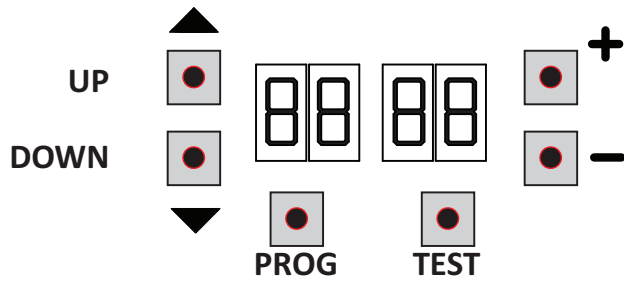

The diagram illustrates the control unit's interface. It features two digital displays, each showing the number '88'. To the left of the displays are two buttons labeled 'UP' (with an upward arrow) and 'DOWN' (with a downward arrow). Below the displays are two buttons labeled 'PROG' and 'TEST'. To the right of the displays are two buttons labeled '+' and '-'.

BUTTON	DESCRIPTION
UP ▲	Next parameter
DOWN ▼	Previous parameter
+	Increase value of parameter by 1
-	Decrease value of parameter by 1
PROG	Programme travel
TEST	Activate TEST mode

- Press the UP ▲ and/or DOWN ▼ buttons to view the parameter you intend to modify.
- Use the + and - buttons to modify the value of the parameter. The value starts to flash.
- Press and hold the + or - button to scroll quickly through values, to modify the parameter more quickly.
- To save the new value, wait a few seconds or move onto another parameter with the UP ▲ or DOWN ▼ button. The display flashes rapidly to indicate that the new value has been saved.
- Parameters can only be modified while the motor is not running. Parameters can be viewed at any time.

## 7 Switching on or commissioning

Power the control unit.

The firmware version of the control unit is displayed briefly.

Version installed: P3.05.

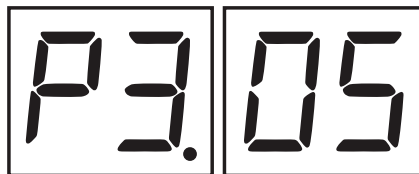

The digital display shows the text 'P3.05' in a large, black, seven-segment font. The 'P' and '3' are on the left, and '05' is on the right, with a period between them.

Immediately afterwards, the display enters the commands and safety device status mode. See chapter 8.

## 8 Display function modes

### 8.1 Parameter display mode

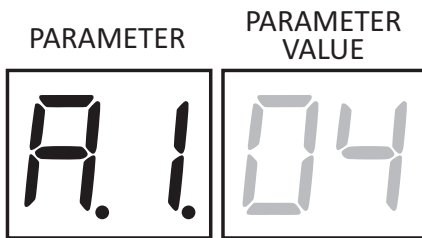

See chapter 11 for detailed descriptions of the parameters.

### 8.2 Command and safety device status display mode

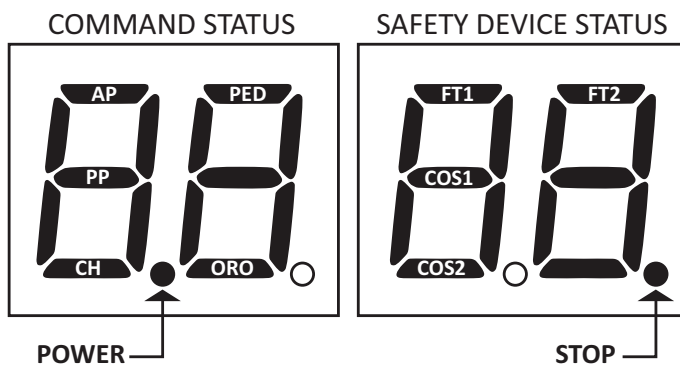

#### COMMAND STATUS:

The command status indicators on the display (segments **AP** = open, **PP** = step mode, **CH** = close, **PED** = partial opening, **ORO** = clock) are normally off. They illuminate when a command is received (e.g.: when a step mode command is received, the segment **PP** illuminates).

#### SAFETY DEVICE STATUS:

The safety device status indicators on the display (segments **FT1/FT2**=photocells, **COS1/COS2** = sensing edges, **STOP**) are normally on. If an indicator is off, the relative device is in alarm state or is not connected.

If an indicator is flashing, the relative device has been disabled with a specific parameter.

### 8.3 TEST mode

The TEST mode is used to test activation of the commands and safety devices with visual confirmation.

To activate the mode, press the TEST button with the automatic gate system at rest. If the gate is moving, pressing TEST stops the gate. Pressing the button again enables TEST mode.

If the flashing light and the gate open indicator lamp illuminate for one second each time a control is used or a safety device is activated.

The command signal status is shown on the left hand side of the display for 5 seconds, ONLY when the respective command signal is active (AP, CH, PP, PE, OR). For example, if the gate open command is activated, the letters AP appear on the display.

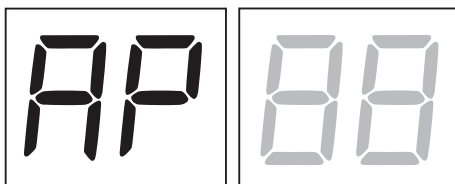

The status of the safety devices/inputs is shown on the right hand side of the display. The number of the terminal relative to the safety device in alarm state flashes.

Example: STOP contact in alarm state.

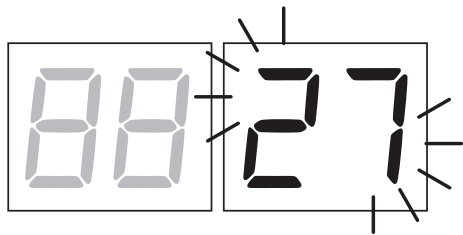

00	No safety device in alarm state, and no limit switch activated
27	STOP.
25	Sensing edge COS1.
24	Sensing edge COS2.
23	Photocell FT1.
22	Photocell FT2.
dAtA	Parameter 7 l modified. Press the PROG key until APP- appears on the display, then repeat the acquisition procedure (see chapter 9).

**NOTA:** If one or more contacts are open, the gate will not open or close.

If more than one safety device is in alarm state, once the problem relative to the first device is resolved, the alarm for the next device is displayed. Any further alarm states are also displayed with the same logic.

Press the TEST button again to exit test mode.

After 10 seconds with no user input, the display returns to command and safety device state display mode.

## 8.4 Standby mode

This mode is activated after 30 minutes with no user input. The POWER LED flashes slowly.

Press UP ▲, DOWN ▼, +, - to reactivate the control unit.

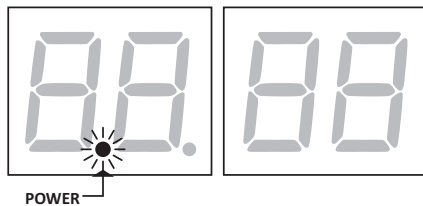

# 9 Travel acquisition



For the system to function correctly, the gate travel must be acquired by the control.

## 9.1 Before starting

1. Select the automation system model installed with the parameter *A1*.

KEY: HIGH SPEED Motor REVERSIBLE Motor

SELECTION	MODEL	MOTOR TYPE	CONFIGURATIONS
<i>A101</i>	BE20 HS		/
<i>A102</i>	BR20	/	/
<i>A103</i>	BH23	/	/
<i>A104</i>	BR21	/	/
<i>A105</i>	SMARTY5 / SMARTY7	/	If <b>SMARTY/EMA</b> is installed, set <i>7101</i> <b>NB:</b> the error message <i>dAtA</i> appears on the display whenever this parameter is modified. Press the PROG key until <i>APP-</i> appears on the display, then repeat the acquisition procedure (see chapter 9.2).
<i>A106</i>	SMARTY 7R		Set <i>5401</i> and <i>7101</i> <b>NB:</b> the error message <i>dAtA</i> appears on the display whenever this parameter is modified. Press the PROG key until <i>APP-</i> appears on the display, then repeat the acquisition procedure (see chapter 9.2).
<i>A107</i>	SMARTY 5R		Set <i>5401</i> and <i>7101</i> <b>NB:</b> the error message <i>dAtA</i> appears on the display whenever this parameter is modified. Press the PROG key until <i>APP-</i> appears on the display, then repeat the acquisition procedure (see chapter 9.2).
<i>A108</i>	SMARTY 4HS		If <b>SMARTY/EMA</b> is installed, set <i>7101</i> <b>NB:</b> the error message <i>dAtA</i> appears on the display whenever this parameter is modified. Press the PROG key until <i>APP-</i> appears on the display, then repeat the acquisition procedure (see chapter 9.2).
<i>A109</i>	BH23 HS		/

2. Select the number of motors installed with the parameter *70*. This parameter is set for two motors by default.

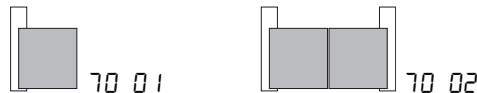

3. Check that the operator present function is not enabled (*A700*).

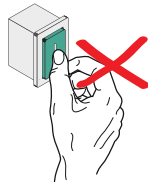

4. Install mechanical stops in both the open and closed positions.
5. Move the gate into the closed position. The gate leaves must be against the mechanical stops.
6. Press **TEST** (see TEST mode in chapter 8) and check the command signal and safety device states. If any safety devices are not installed, jumper the relative contact or disable the device from the relative parameter (*50*, *51*, *53*, *54*, *73* and *74*).



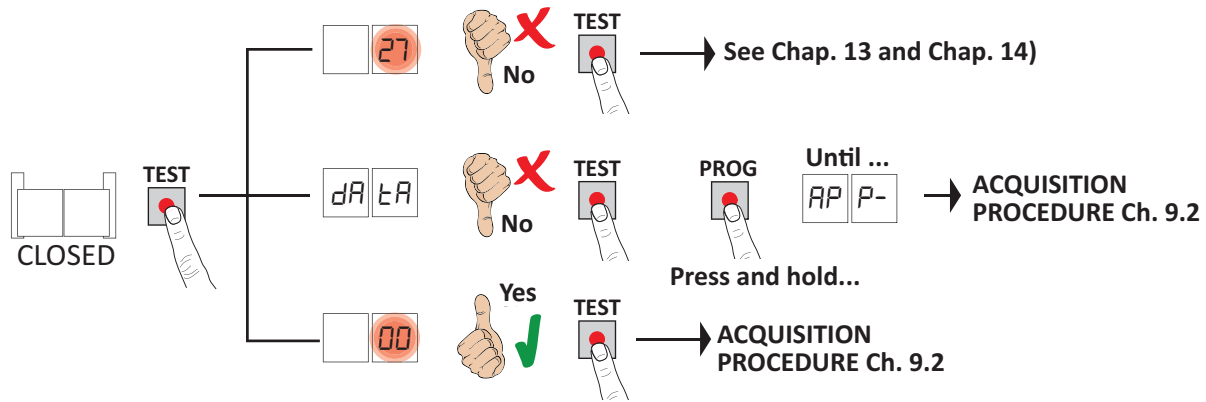

## 9.2 Acquisition procedure:

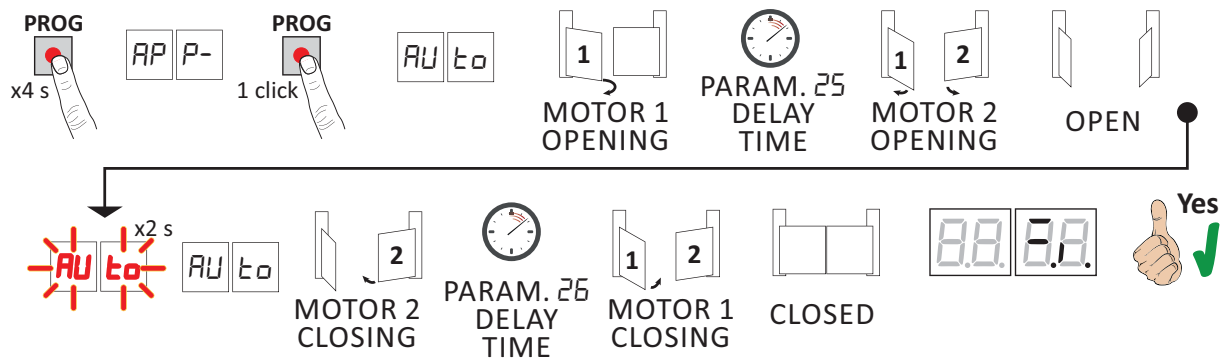

- Press and hold **PROG** for 4 seconds. *AP P-* is shown on the display.
- Press **PROG** again. *AU t0* is shown on the display.
- MOTOR 1 starts opening at low speed.
- After the delay time set with parameter *25* (with a default time setting of 3 s), MOTOR 2 starts an opening manoeuvre.
- Once the gate open mechanical stop is reached, the gate stops briefly. The message *AU t0* flashes on the display for 2 s.
- When the message *AU t0* stops flashing and is steadily lit on the display, MOTOR 2 closes first and then, after a delay set with parameter *26* (default setting 5 s), MOTOR 1 closes until the gate closed mechanical stop is reached.

If the acquisition procedure is completed successfully, the display enters the command and safety device state display mode.

If the following error messages are shown on the display, repeat the acquisition procedure:

- *AP PE*: acquisition error. Press the TEST button to clear the error, and check the safety device in alarm state.
- *AP PL*: travel length error. Press TEST to clear the error, and check that both gate leaves are fully closed before launching a new acquisition procedure.



**For more information, see chapter 14 “Alarms and faults”.**

# 10 Index of parameters

PARAM.	FACTORY DEFAULT	DESCRIPTION	PAGE
A1	04	Selecting automation system model (SEE CHAPTER 11)	53
A2	00	Automatic closure after pause time (from gate completely open)	53
A3	00	Automatic gate closing after mains power outage (black-out)	53
A4	00	Selecting step mode control function (PP)	53
A5	00	Pre-flashing	54
A6	00	Condominium function for partial open command (PED)	54
A7	00	Enabling operator present function.	54
A8	00	Gate open indicator / photocell test function and "battery saving"	54
11	04	MOTOR 1 Setting deceleration during opening and closing	54
12	04	MOTOR 2 Setting deceleration during opening and closing	54
13	10	Adjusting LEAF 1 position control	54
14	10	Adjusting LEAF 2 position control	54
15	99	Partial opening adjustment (%)	55
19	00	Adjusting MOTOR 1 stop advance on gate open stop	55
20	00	Adjusting MOTOR 2 stop advance on gate open stop	55
21	30	Setting automatic closing time	55
22	00	Enabling of management for opening with automatic reclosure exclusion	55
25	03	Adjusting opening delay of MOTOR 2	55
26	05	Adjusting closing delay of MOTOR 1	55
27	03	Setting reverse time after activation of sensing edge or obstacle detection (crush prevention).	55
28	00	Electric lock mode selection	55
29	00	Enable electric lock	55
30	07	Setting motor torque	56
31	15	Setting obstacle impact force sensitivity MOTOR 1	56
32	15	Setting obstacle impact force sensitivity MOTOR 2	56
33	10	Setting motor torque MOTOR 2	56
34	08	Setting start acceleration during opening and closing MOTOR 1	56
35	08	Setting start acceleration during opening and closing MOTOR 2	56
38	00	Enable lock release reverse impulse	56
40	04	Speed opening setting	57
41	04	Speed closing setting	57
49	01	Number of automatic closure attempts after activation of sensing edge or obstacle detection (crush protection)	57
50	00	Setting photocell mode during gate opening (FT1)	57
51	02	Setting photocell mode during gate closing (FT1)	57
52	01	Photocell (FT1) mode with gate closed	57
53	00	Setting photocell mode during gate opening (FT2)	57
54	00	Setting photocell mode during gate closing (FT2)	58
55	01	Photocell (FT2) mode with gate closed	58
56	00	Enable close command 6 s after activation of photocell (FT1-FT2)	58
57	00	Selecting contact type (NC or 8.2 kOhm) on inputs FT1/FT2/ST	58

PARAM.	FACTORY DEFAULT	DESCRIPTION	PAGE
58	00	Selecting the type of photocell test on input FT1	58
59	00	Selecting the type of photocell test on input FT2	58
64 	00	Managing reversible function of motor (SMARTY REVERSIBLE only)	59
65	05	Motor stop distance setting	59
70	02	Select number of motors installed	59
71	00	Enabling absolute encoder (SMARTY Series automation systems only)	59
73	03	Configuring sensing edge COS1	59
74	00	Configuring sensing edge COS2	59
76	00	Configuring radio channel 1 (PR1)	60
77	01	Configuring radio channel 2 (PR2)	60
78	00	Configuring flashing light frequency	60
79	60	Selecting courtesy light mode	60
80	00	Clock contact configuration ORO/IN1	60
81	00	Enable safeguarded gate closure/opening	61
82	03	Setting safeguarded closure/opening activation time	61
85	02	Reduced performance for battery power mode	61
86	00	Enabling of regular maintenance activation	61
87	00	Adjustment of regular maintenance activation hour counter	62
90	00	Restoring factory default values	62
r0	01	HW version	62
r1	23	Year of manufacture	62
r2	45	Week of manufacture	62
r3	67		62
r4	89	Serial number	62
r5	01		62
r6	23	FW version	62
o0	01	View manoeuvre counter	62
o1	23		62
h0	01	View manoeuvre hour counter	63
h1	23		63
d0	01	View control unit days on counter	63
d1	23		63
P1	00		63
P2	00	Password	63
P3	00		63
P4	00		63
CP	00	Password change protection	63

# 11 Parameters menu

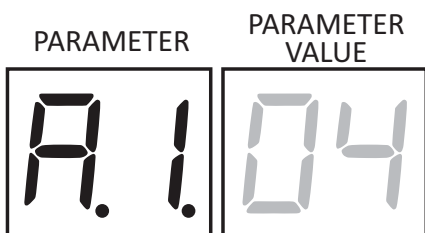

PARAMETER	PARAMETER VALUE
<b>A1 04</b>	<b>Selecting automation system model</b> <b>WARNING!</b> If this parameter is not set correctly, the automation system may not function properly. <b>N.B.:</b> in the event of a reset to restore the default parameters, this parameter must be set again manually.
01	<b>BE20 HS</b> range - <b>IRREVERSIBLE HIGH-SPEED</b> piston for gate leaves up to 2.5m.
02	<b>BR20</b> range - <b>IRREVERSIBLE</b> piston for gate leaf lengths from 2,5 to 3,5 m.
03	<b>BH23</b> range - Gear motor with <b>IRREVERSIBLE</b> articulated arm for gate leaf lengths up to 2,8 m.
04	<b>BR21</b> range - In-ground <b>IRREVERSIBLE</b> gear motor for gate leaf lengths up to 3,5 m.
05	<b>SMARTY 5</b> or <b>SMARTY 7</b> range - Irreversible piston for gate leaf lengths up to 5 or up to 7 m.
06	<b>SMARTY 7R</b> range - <b>REVERSIBLE</b> piston for gate leaf lengths up to 7 m. <b>IMPORTANT:</b> set 64 01 and 71 01.
07	<b>SMARTY 5R</b> range - <b>REVERSIBLE</b> piston for gate leaf lengths up to 5 m. <b>IMPORTANT:</b> set 64 01 and 71 01.
08	<b>SMARTY 4HS</b> range - <b>IRREVERSIBLE HIGH-SPEED</b> piston for gate leaves up to 4m.
09	<b>BH23 HS</b> range - Gear motor with <b>IRREVERSIBLE HIGH-SPEED</b> articulated arm for gate leaf lengths up to 2,5 m
<b>A2 00</b>	<b>Automatic closure after pause time (from gate completely open)</b>
00	Disabled.
01-15	From 1 to 15 of gate closure attempts after photocell is triggered. Once the number of attempts set is reached, the gate remains open.
99	The gate tries to close indefinitely.
<b>A3 00</b>	<b>Automatic gate closing after mains power outage</b>
00	Disabled. The gate does not close automatically when mains power is restored.
01	Enabled. If the gate is NOT completely open, when mains power is restored, the gate closes after a 5 second warning signalled with the flashing light (independently of the value set with the parameter A5). The gate closes in "position recovery" mode (see chapter 17-18).
<b>A4 00</b>	<b>Selecting step mode control function (PP)</b>
00	Open-stop-close-stop-open-stop-close...
01	Condominium function: the gate opens and closes after the set automatic closing time. The automatic closing timer restarts if a new step mode command is received. Step mode commands are ignored while the gate is opening. This allows the gate to open completely and prevents the gate from closing when not required. If automatic closing is disabled (A2 00), the condominium function automatically attempts a closing manoeuvre A2 01.
02	Condominium function: the gate opens and closes after the set automatic closing time. The automatic closing timer does NOT restart if a new step mode command is received. Step mode commands are ignored while the gate is opening. This allows the gate to open completely and prevents the gate from closing when not required. If automatic closing is disabled (A2 00), the condominium function automatically attempts a closing manoeuvre A2 01.
03	Open-close-open-close.
04	Open-close-stop-open.

EN

<b>A5 00</b>	<b>Pre-flashing</b>
00	Disabled. The flashing light is activated during opening and closing manoeuvres.
01-10	Flashing warning signal for 1 to 10 seconds prior to every manoeuvre.
99	5 second flashing warning signal prior to closing manoeuvre.
<b>A6 00</b>	<b>Condominium function for partial open command (PED)</b>
00	Disabled. The gate opens partially in step mode: open-stop-close-stop-open...
01	Enabled. Partial commands are ignored during gate opening.
<b>A7 00</b>	<b>Enabling operator present function.</b>
00	Disabled.
01	Enabled. The open (AP) or close (CH) button must be pressed continuously to operate the gate. The gate stops when the button is released.
<b>A8 00</b>	<b>Gate open indicator / photocell test function and "battery saving"</b>
00	The indicator is off when the gate is closed, and steadily lit during manoeuvres and when the gate is open.
01	The indicator flashes slowly during opening manoeuvres, and is lit steadily when the gate is completely open. It flashes quickly during closing manoeuvres. If the gate is stopped in an intermediate position, the lamp extinguishes twice every 15 seconds.
02	Set 02 if the output <b>SC</b> is used for the photocell test. See fig. 5. <b>NB:</b> the type of photocell test can be selected by means of parameters 58 and 59.
03	Set to 03 if the output <b>SC</b> is used for the "battery saving" function. See fig. 6. When the gate is completely open or closed, the control unit deactivates any accessories connected to terminal <b>SC</b> to reduce battery consumption.
04	Set to 04 if the output <b>SC</b> is used for the "battery saving" function and photocell test function. See fig. 6. <b>NB:</b> the type of photocell test can be selected by means of parameters 58 and 59.
<b>11 04</b>	<b>Setting deceleration MOTOR 1 during opening and closing</b>
<b>12 04</b>	<b>Setting deceleration MOTOR 2 during opening and closing</b>
01-05	01= the gate decelerates near stops and the limit switch (if installed). ... 05= the gate decelerates long before stops and the limit switch (if installed).
<b>13 10</b>	<b>Adjusting LEAF 1 position control when completely opens or closes</b> The value selected must ensure that LEAF 1 is opened/closed correctly when it reaches the respective (open or closed) mechanical stop. The position of LEAF 1 is calculated by the system from the number of motor revolutions and the motor reduction gear ratio. <b>Warning!</b> Excessively low values cause the gate to reverse when it reaches the gate open stop. <b>N.B.:</b> with <b>BR21</b> automation systems, with the gate leaf in the completely closed position, adjust the inner mechanical stop so that the lever of the gear motor can move by a few millimetres.
<b>14 10</b>	<b>Adjusting LEAF 2 position control when completely opens or closes</b> The value selected must ensure that LEAF 2 is opened/closed correctly when it reaches the respective (open or closed) mechanical stop. The position of LEAF 2 is calculated by the system from the number of motor revolutions and the motor reduction gear ratio. <b>Warning!</b> Excessively low values cause the gate to reverse when it reaches the gate closed stop. <b>N.B.:</b> with <b>BR21</b> automation systems, with the gate leaf in the completely closed position, adjust the inner mechanical stop so that the lever of the gear motor can move by a few millimetres.
01-20	Motor revolutions (01 = minimum / 20 = maximum).

15 99	<b>Partial opening adjustment (%)</b> N.B.: with double leaf swing gate installations, this parameter is set by default as the completely open position of LEAF 1. With single leaf swing gate installations, this parameter is set to 50% of total opening.
15-99	From 15% to 99% of total gate travel.
19 00	<b>Adjusting stop advance of LEAF 1 when opening</b>
20 00	<b>Adjusting stop advance of LEAF 2 when opening</b>
00	The leaf stops against the opening stop.
01-25	A leaf stop advance of 1 to 25 motor turns before the completely open position may be set.
21 30	<b>Setting automatic closing time</b> The timer starts from the gate open state and continues for the set time. Once the set time is reached, the gate closes automatically. The timer count restarts if a photocell is triggered. IMPORTANT: persistent activation of the opening command prevents automatic reclosure; the automatic reclosure time count is resumed when the opening command is released.
00-90	Pause time settable from 00 to 90 s.
92-99	Pause time settable from 2 to 9 min.
22 00	<b>Enabling of management for opening with automatic reclosure exclusion.</b> If enabled, the exclusion of automatic reclosure only applies for the command selected via the parameter. <b>For example:</b> if you set 220 1, automatic reclosure is excluded following an AP command, but it is activated following a PP or PED command. NB: a command activates a manoeuvre in the open-stop-close or close-stop-open sequence.
00	Disabled.
01	An AP (opening) command activates the opening manoeuvre. With the gate fully open, automatic reclosure is excluded. An AP (open) or CH (close) command activates the closure manoeuvre.
02	With the gate closed, a PP (step mode) command activates the opening manoeuvre. With the gate fully open, automatic reclosure is excluded. Another PP (step mode) command activates the closure manoeuvre.
03	With the gate closed, a PED (partial opening) command activates the partial opening manoeuvre. Automatic reclosure is excluded. Another PED (partial opening) command activates the closure manoeuvre.
25 03	<b>Adjusting opening delay (alignment) of MOTOR 2</b> During opening, MOTOR 2 starts with an adjustable delay after MOTOR 1.
00-10	From 0 to 10 s.
26 05	<b>Adjusting closing delay (alignment) of MOTOR 1</b> During closing, MOTOR 1 starts with an adjustable delay after MOTOR 2.
00-30	From 0 to 30 s.
27 03	<b>Setting reverse time after activation of sensing edge or obstacle detection (crush prevention).</b> This sets the reverse manoeuvre time after activation of the sensing edge or the obstacle detection system.
00-60	From 0 to 60 s.
28 00	<b>Electric lock mode selection</b>
00	Normally UNPOWERED electric lock (powered only for 3 s when opening starts). N.B.: The electric lock is enabled by parameter 29.
01	“ventouse” type electric block (normally powered when the gate is completely closed). Not powered when gate is moving.
02	“ventouse” type electric block (normally powered when the gate is completely opened or completely closed). Not powered when gate is moving.



<b>29 00</b>	<b>Enable electric lock</b>
00	Disabled.
01	Enabled. When LEAF 1 approaches the gate closed stop, the controller delivers supplementary power to MOTOR 1 to latch the electric lock.
02	Enabled. When LEAF 1 approaches the gate closed stop, the controller delivers maximum power to MOTOR 1 to latch the electric lock. The obstacle detection system is disabled.
<b>30 07</b>	<b>Setting motor torque</b> Increasing or decreasing the value of the parameter increases or decreases motor torque and, as a result, adjusts obstacle detection sensitivity. Use values below 03 SOLO ONLY for particularly lightweight installations not exposed to severe weather conditions (strong winds or very cold temperatures). In installations with gate leaves of different lengths, they torque value may be set separately, setting a value for parameter 33 between 01 and 09.
01-09	01= -35%; 02= -25%; 03= -16%; 04= -8% (reduced motor torque = increased sensitivity). 05= 0%. 06= +8%; 07= +16%; 08= +25%; 09= +35% (increased motor torque = reduced sensitivity).
<b>31 15</b>	<b>Setting obstacle impact force sensitivity MOTOR 1</b> If the reaction time to obstacle impact force is too long, reduce the value of the parameter. If the impact force exerted on obstacles is too high, reduce the value of parameter 30. <b>N.B.:</b> repeat the acquisition procedure after any change made to this parameter.
01-10	Low motor torque: 01 = minimum obstacle impact force ... 10 = maximum obstacle impact force <b>N.B.:</b> only use these settings if the medium motor torque values are not suitable for the installation.
11-19	Medium motor torque. <b>Recommended setting for adjusting force settings correctly.</b> 11 = minimum obstacle impact force ... 19 = maximum obstacle impact force.
20	Maximum motor torque. May only be used if the gate is equipped with a sensing edge.
<b>32 15</b>	<b>Setting obstacle impact force sensitivity MOTOR 2</b> If the reaction time to obstacle impact force is too long, reduce the value of the parameter. If the impact force exerted on obstacles is too high, reduce the value of parameter 30 (or 33, if enabled: 33 different from 10). <b>N.B.:</b> repeat the acquisition procedure after any change made to this parameter.
01-10	Low motor torque: 01 = minimum obstacle impact force ... 10 = maximum obstacle impact force <b>N.B.:</b> only use these settings if the medium motor torque values are not suitable for the installation.
11-19	Medium motor torque. <b>Recommended setting for adjusting force settings correctly.</b> 11 = minimum obstacle impact force ... 19 = maximum obstacle impact force.
20	Maximum motor torque. May only be used if the gate is equipped with a sensing edge.
<b>33 10</b>	<b>Setting motor torque MOTOR 2</b> Increasing or decreasing the value of the parameter increases or decreases motor torque and, as a result, adjusts obstacle detection sensitivity. Use values below 03 SOLO ONLY for particularly lightweight installations not exposed to severe weather conditions (strong winds or very cold temperatures).
01-09	01= -35%; 02= -25%; 03= -16%; 04= -8% (reduced motor torque = increased sensitivity). 05= 0%. 06= +8%; 07= +16%; 08= +25%; 09= +35% (increased motor torque = reduced sensitivity).
10	The torque is set with parameter 30.
<b>34 08</b>	<b>Setting start acceleration MOTOR 1 during opening and closing</b>
<b>35 08</b>	<b>Setting start acceleration MOTOR 2 during opening and closing</b>
01-10	01= the gate accelerates rapidly at start of manoeuvre. ... 10= the gate accelerates slowly and progressively at start of manoeuvre.

<b>38 00</b>	<b>Enable electric lock release reverse impulse</b>
00	Disabled.
01	Enabled. The controller applies a brief closing force (max. 4 s) to release the electric lock.
<b>40 04</b>	<b>Setting opening speed (%)</b>
<b>41 04</b>	<b>Setting closing speed (%)</b>
01-05	01= 60% minimum speed ... 05= 100% maximum speed.
<b>49 01</b>	<b>Setting number of automatic closure attempts after activation of sensing edge or obstacle detection (crush protection)</b>
00	No automatic closure attempts.
01-03	From 1 to 3 automatic closure attempts. We recommend setting a value equal to or lower than the value set for parameter <i>A2</i> . Automatic closure is only performed if the gate is completely open.
<b>50 00</b>	<b>Setting photocell mode during gate opening (FT1)</b>
00	DISABLED. Photocell is not active or not installed.
01	STOP. The gate stops and remains stationary until the next command is received.
02	IMMEDIATE REVERSE. The gate reverses immediately if the photocell is activated during gate opening.
03	TEMPORARY STOP. The gate stops as long as the photocell is obstructed. The gate resumed opening when the photocell is cleared.
04	DELAYED REVERSE. The gate stops if the photocell is obstructed. The gate closes when the photocell is cleared.
<b>51 02</b>	<b>Setting photocell mode during gate closing (FT1)</b>
00	DISABLED. Photocell is not active or not installed.
01	STOP. The gate stops and remains stationary until the next command is received.
02	IMMEDIATE REVERSE. The gate reverses immediately if the photocell is activated during gate closure.
03	TEMPORARY STOP. The gate stops as long as the photocell is obstructed. The gate resumed closing when the photocell is cleared.
04	DELAYED REVERSE. The gate stops if the photocell is obstructed. The gate opens when the photocell is cleared.
<b>52 01</b>	<b>Photocell (FT1) mode with gate closed</b> <b>N.B.:</b> this parameter is not visible if <i>A802</i> or <i>A803</i> or <i>A804</i> is set.
00	If the photocell is obstructed, the gate cannot open.
01	The gate opens when an open command is received, even if the photocell is obstructed.
02	The photocell sends the gate open command when obstructed.
<b>53 00</b>	<b>Setting photocell mode during gate opening (FT2)</b>
00	DISABLED. Photocell is not active or not installed.
01	STOP. The gate stops and remains stationary until the next command is received.
02	IMMEDIATE REVERSE. The gate reverses immediately if the photocell is activated during gate opening.
03	TEMPORARY STOP. The gate stops as long as the photocell is obstructed. The gate resumed opening when the photocell is cleared.
04	DELAYED REVERSE. The gate stops if the photocell is obstructed. The gate closes when the photocell is cleared.

<b>54 00</b>	<b>Setting photocell mode during gate closing (FT2)</b>		
00	DISABLED. Photocell is not active or not installed.		
01	STOP. The gate stops and remains stationary until the next command is received.		
02	IMMEDIATE REVERSE. The gate reverses immediately if the photocell is activated during gate closure.		
03	TEMPORARY STOP. The gate stops as long as the photocell is obstructed. The gate resumed closing when the photocell is cleared.		
04	DELAYED REVERSE. The gate stops if the photocell is obstructed. The gate opens when the photocell is cleared.		
<b>55 01</b>	<b>Photocell (FT2) mode with gate closed</b> N.B.: this parameter is not visible if <i>AB02</i> or <i>AB03</i> or <i>AB04</i> is set.		
00	If the photocell is obstructed, the gate cannot open.		
01	The gate opens when an open command is received, even if the photocell is obstructed.		
02	The photocell sends the gate open command when obstructed.		
<b>56 00</b>	<b>Enable close command 6 s after activation of photocell (FT1-FT2)</b> N.B.: This parameter is not visible if <i>AB 03</i> or <i>AB 04</i> is set.		
00	Disabled.		
01	Enabled. When the photocell gate FT1 is crossed, a close command is sent 6 seconds later.		
02	Enabled. When the photocell gate FT2 is crossed, a close command is sent 6 seconds later.		
<b>57 00</b>	<b>Selecting contact type (NC or 8.2 kOhm) on inputs FT1/FT2/ST</b> In conformity with the safety regulations EN12453-EN12445, devices using an 8.2 kOhm contact instead of an NC contact may be connected to inputs FT1/FT2/ST. The controller unit must therefore be configured accordingly.		
	<b>FT1</b>	<b>FT2</b>	<b>ST</b>
00	The controller is configured for NC contacts by default.		
01	8k2	N.C.	N.C.
02	N.C.	8k2	N.C.
03	8k2	8k2	N.C.
10	N.C.	N.C.	8k2
11	8k2	N.C.	8k2
12	N.C.	8k2	8k2
13	8k2	8k2	8k2
<b>58 00</b>	<b>Selecting the type of photocell test on input FT1</b> This parameter is visible if <i>AB02</i> or <i>AB04</i> is set. If the photocell test is enabled, the control unit will check the photocells connected to input FT1 are working properly. The test lasts max. 3 s OFF / 3 s ON.		
<b>59 00</b>	<b>Selecting the type of photocell test on input FT2</b> This parameter is visible if <i>AB02</i> or <i>AB04</i> is set. If the photocell test is enabled, the control unit will check the photocells connected to input FT2 are working properly. The test lasts max. 3 s OFF / 3 s ON.		
00	Photocell test disabled.		
01	Photocell test enabled on opening ONLY.		
02	Photocell test enabled on closure ONLY.		
03	Photocell test enabled on both opening and closure.		

64 00	<b>Method and management of SMARTY 5R- SMARTY 7R automation reversibility</b> 
	This parameter is visible ONLY if A1 06 or A1 07. <b>NOTE:</b> Even though it is a REVERSIBLE unit, the motor is equipped with a lock release system.
00	The <b>SMARTY 5R/7R</b> motor is always <b>REVERSIBLE</b> . The gate leaf may be moved manually in either direction (open or close) without unlocking the motor, with or without mains power, when the motor is not running. <b>WARNING:</b> when the control unit is powered, consider the possibility of an electric lock.
01	The SMARTY 5R/7R motor is <b>REVERSIBLE ONLY</b> when the controller is NOT powered. When the control unit is powered, SMARTY 5R/7R is <b>IRREVERSIBLE</b> during both opening and closure. If the unit is not powered, the gate leaf can be moved manually without releasing the motor (in both opening and closure). <b>WARNING:</b> when the control unit is NOT powered, consider the possibility of an electric lock. <b>IMPORTANT!</b> Always disconnect from mains power and (if applicable) battery power before disconnecting the terminal board of the motor from the controller or disconnecting any of the motor wires.
<b>65 05 Setting motor stop distance</b>	
01-05	01= faster deceleration/shorter stop distance ... 05= slower deceleration/longer stop distance.
<b>70 02 Select number of motors installed</b>	
	<b>N.B.:</b> if SMARTY REVERSIBLE MOTOR are used, whenever this parameter is modified repeat the acquisition procedure (see chapter 9).
01	1 motor.
02	2 motors. <b>IMPORTANT:</b> Use the same type of motor for both gate leaves.
<b>71 00 Enabling absolute encoder (SMARTY Series automation systems only)</b>	
	<b>Attention: the parameter 71 01 must be set for all applications with the SMARTY REVERSIBLE motor.</b> <b>NB:</b> the error message <i>dALR</i> appears on the display whenever this parameter is modified. Press the PROG key until <i>APP-</i> appears on the display, then repeat the acquisition procedure (see chapter 9.2).
00	Disabled.
01	Enabled. Perform or repeat the acquisition procedure to acquire the parameters relative to the installation. <b>N.B:</b> see chapter 12 for more information on the absolute encoder.
<b>73 03 Configuring sensing edge COS1</b>	
00	Sensing edge NOT INSTALLED.
01	NC contact (normally closed). The gate reverses only when opening.
02	Contact with 8k2 resistor. The gate reverses only when opening.
03	NC contact (normally closed). The gate always reverses.
04	Contact with 8k2 resistor. The gate always reverses.
<b>74 00 Configuring sensing edge COS2</b>	
00	Sensing edge NOT INSTALLED.
01	NC contact (normally closed). The gate reverses only when closing.
02	Contact with 8k2 resistor. The gate reverses only when closing.
03	NC contact (normally closed). The gate always reverses.
04	Contact with 8k2 resistor. The gate always reverses.

<b>76 00</b>	<b>Configuring radio channel 1 (PR1)</b>
<b>77 01</b>	<b>Configuring radio channel 2 (PR2)</b>
00	STEP MODE.
01	PARTIAL OPENING
02	OPENING
03	CLOSING.
04	STOP.
05	Courtesy light. The output COR is managed from the remote control. The light remains lit as long as the remote control is active. The parameter 79 is ignored.
06	Courtesy light ON-OFF (PP). The output COR is managed from the remote control. The remote control turns the courtesy light on and off. The parameter 79 is ignored.
07	STEP MODE with confirmation for safety. <sup>(1)</sup>
08	PARTIAL OPENING with confirmation for safety. <sup>(1)</sup>
09	OPENING with confirmation for safety. <sup>(1)</sup>
10	CLOSURE with confirmation for safety. <sup>(1)</sup>

<sup>(1)</sup> To prevent gate manoeuvres caused by accidentally pressing a remote control button, confirmation is required to enable the command. Example: parameters 76 07 and 77 01 set:

- Pressing the CHA button on the remote control selects the step mode function, which must be confirmed within 2 seconds by pressing CHB on the remote control. Press CHB to activate partial opening.

<b>78 00</b>	<b>Configuring flashing light frequency</b>
00	The frequency is set electronically from the flashing light unit.
01	Slow flash.
02	Light flashes slowly when gate opens, rapidly when gate closes.

<b>79 60</b>	<b>Selecting courtesy light mode</b>
00	Disabled.
01	PULSE. The courtesy light illuminates briefly at the start of each manoeuvre.
02	ACTIVE. The light remains lit for the entire duration of the manoeuvre.
03-90	From 3 to 90 s. The light remains lit for the time period set after the manoeuvre is completed.
92-99	From 2 to 9 minutes. The light remains lit for the time period set after the manoeuvre is completed.

<b>80 00</b>	<b>Clock contact configuration (ORO)</b> When the clock function is active, the gate opens and remains open. At the end of the programmed time set with the external device (clock), the gate closes.
00	When the clock function is active, the gate opens and remains open. Any command signal received is ignored.
01	When the clock function is active, the gate opens and remains open. Any command signal received is accepted. When the gate returns to the completely open position, the clock function is reactivated.

<b>8100</b>	<b>Enable safeguarded gate closure/opening</b> Enabling this parameter ensures that the gate is not left open due to an incorrect and/or accidental command. This function is <u>NOT</u> enabled if: <ul style="list-style-type: none"> <li>• the gate receives a STOP command;</li> <li>• the sensing edge is activated;</li> <li>• the number of closure attempts set by parameter <i>A2</i> has been reached;</li> <li>• the acquired position is lost (perform position recovery, see chapter 17-18).</li> </ul>
00	Disabled. The parameter <i>B2</i> is not displayed.
01	Safeguarded closure enabled. After a period of time set with parameter <i>B2</i> , the control unit signals a 5 second warning with the flashing light, regardless of the parameter <i>A5</i> , and then closes the gate.
02	Safeguarded closure / opening enabled. If the gate is closed as a result of a step mode command, after a period of time set with parameter <i>B2</i> , the control unit signals a 5 second warning with the flashing light (regardless of the parameter <i>A5</i> ), and then the gate closes. If the gate is stopped by the obstacle detection system during a closure manoeuvre, the gate closes after a period of time set with parameter <i>B2</i> . If the gate is stopped by the obstacle detection system during an opening manoeuvre, the gate closes after a period of time set with parameter <i>B2</i> .
<b>8203</b>	<b>Setting safeguarded closure/opening activation time</b> <b>N.B.:</b> this parameter is not visible if the value of parameter <i>B1</i> = 00.
02-90	Wait time settable from 2 to 90 s.
92-99	Wait time settable from 2 to 9 min.
<b>8502</b>	<b>Reduced performance for battery power mode</b> To prevent problems in battery power mode caused by excessively high acceleration and speed settings, the controller unit automatically reduces performance when it detects that mains power is absent.
00	<b>No reduction.</b> The acceleration (34/35), deceleration (11/12) and speed (40/41) parameters configured are maintained.
01	<b>BASIC reduced performance mode.</b> Acceleration 34/35 slow=08. Deceleration 11/12 gradual=04. Speed 40/41 70%02.
02	<b>ADVANCED reduced performance mode.</b> Acceleration 34/35 slow=08. Deceleration 11/12 gradual=04. Speed 40/41 60%02.
<b>8600</b>	<b>Enabling of regular maintenance activation</b> <b>N.B.:</b> Parameter visible if any password other than the default password is set (Parameter <i>P1</i> = <i>P4</i> ). <b>N.B.:</b> in the event of a reset to restore the default parameters, this parameter must be set again manually. When the manoeuvre hour limit (set by <i>B6</i> and <i>B7</i> ) is exceeded, the visual maintenance signal is activated (e.g. every 1500 manoeuvre hours). <b>IMPORTANT:</b> "manoeuvre" means every motor opening activation . The message <i>A55E</i> is shown on the display and the flashing light, with the motors stop, flashes with a regular duty cycle (1 s on / 4 s off) until system maintenance is performed and the alarm is reset. To reset the alarm, deactivate the password ( <i>CP</i> 00) and press TEST for 5 s. The message <i>A55E</i> is displayed, followed by the messages <i>UPdE</i> flashing for 4 seconds: to reset the alarm, hold down the TEST key until <i>donE</i> is displayed. If the TEST key is released, <i>AbrE</i> appears on the display and the alarm is not reset. The number of hours <i>H0-H1</i> is stored by the control unit, and the count is reset. <b>N.B.:</b> When 9990 hours of operation are exceeded, the maintenance alarm is disabled entirely.
00	Disabled.
01	Maintenance enabled for a period = parameter value <i>B7</i> x10 hours.
02	Maintenance enabled for a period = parameter value <i>B7</i> x100 hours.

87 00	<b>Adjustment of regular maintenance activation hour counter</b> N.B: Parameter visible with parameter 86 01 or 86 02. N.B.: in the event of a reset to restore the default parameters, this parameter must be set again manually.
00	Disabled.
01-99	from 10 to 990 hours with parameter 86 01. from 100 to 9900 hours with parameter 86 02. Maximum limit: 9990 hours (beyond this value the maintenance alarm is disabled entirely).

90 00	<b>Restoring factory default values</b> NOTE This procedure is only possible if NO data protection password is set.
-------	--

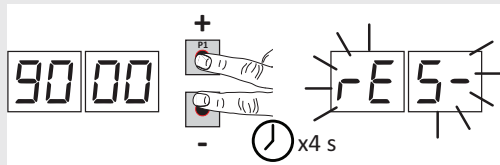

**Warning!** Restoring default settings cancels all settings made previously except for parameter A1 : after restore, check that all parameters are suitable for the installation.  
The default factory settings may also be restored using the + (PLUS) and/or - (MINUS) buttons as follows:

- Turn off the power.
- Press and hold the + (PLUS) and/or - (MINUS) button until the unit switches on.
- The display flashes after 4 s rE5-.
- The default factory settings have now been restored.

	<b>Identification number</b> The identification number consists of the values of the parameters from n0 to n6. N.B.: The values shown in the table are indicative only.
--	---

n0 01	HW version.	Example: 01 23 45 67 89 01 23
n1 23	Year of manufacture.	
n2 45	Week of manufacture.	
n3 67		
n4 89	Serial number.	
n5 01		
n6 23	FW version.	

	<b>View manoeuvre counter</b> The number consists of the values of the parameters from a0 to a1 multiplied by 100. N.B.: The values shown in the table are indicative only. <b>IMPORTANT:</b> "manoeuvre" means every motor activation (total opening or closure / partial opening / step mode, etc.).
--	---

a0 01	Manoeuvres performed.
a1 23	Example: 01 23 x100 = 12.300 manoeuvres.



### View manoeuvre hour counter

The number consists of the values of the parameters from *h0* to *h1*.

**N.B.:** The values shown in the table are indicative only.

When the manoeuvre hour limit (set by *B5* and *B7*) is exceeded, the visual maintenance signal is activated (e.g. every 1500 manoeuvre hours).

**IMPORTANT:** "manoeuvre" means every motor opening activation.

The message *ASSt* is shown on the display and the flashing light, with motors stop, flashes with a regular duty cycle (1 s on / 4 s off) until system maintenance is performed and the alarm is reset.

To reset the alarm, deactivate the password (*CP 00*) and press TEST for 5 s. The message *ASSt* is displayed, followed by the messages *UPdt* flashing for 4 seconds: to reset the alarm, hold down the TEST key until *donE* is displayed.

If the TEST key is released, *Abrt* appears on the display and the alarm is not reset.

The number of hours *H0-H1* is stored by the control unit, and the count is reset.

If the value *H0=99 H1=90* is exceeded (9990 hours of operation) the maintenance alarm is no longer managed.

*h001*

**Manoeuvre hours.**

*h123*

Example: *01 23* = 123 hours.

### View control unit days on counter

The number consists of the values of the parameters from *d0* to *d1*.

**N.B.:** The values shown in the table are indicative only.

*d001*

**Days with unit switched on.**

*d123*

Example: *01 23* = 123 days.

### Password

Setting a password prevents unauthorised persons from accessing the settings.

With password protection active (*CP=01*), parameters may be viewed, but the values CANNOT be modified.

Only a single password is used to control access to the gate automation system.

**WARNING:** Contact the Technical Support Service if you lose your password.

*P100*

**Password activation procedure:**

*P200*

- Enter the desired values for parameters *P1*, *P2*, *P3* and *P4*.

*P300*

- Use the UP ▲ and/or DOWN ▼ buttons to view the parameter *CP*.

*P400*

- Press and hold the + and - buttons for 4 seconds.

- The display flashes to confirm that the password has been saved.

- Switch the control unit off and on again. Check that password protection is activated (*CP=01*).

**Temporary unlock procedure:**

- Enter the password.

- Check that *CP=00*.

**Password cancellation procedure:**

- Enter the password (*CP=00*).

- Save the values *P1*, *P2*, *P3*, *P4* = *00*

- Use the UP ▲ and/or DOWN ▼ buttons to view the parameter *CP*.

- Press and hold the + and - buttons for 4 seconds.

- The display flashes to confirm that the password has been cancelled (the values *P1 00*, *P2 00*, *P3 00* and *P4 00* indicate that no password is set).

- Switch the control unit off and on again (*CP=00*).

*CP 00*

**Changing password**

*00*

Protection deactivated.

*01*









Protection activated.









## 12 Commands and Accessories

 If not installed, safety devices with NC contacts must be jumpered at the COM terminals, or disabled by modifying the parameters 50, 51, 53, 54, 73 and 74.

KEY: N.A. (Normally Open) .  
N.C. (Normally Closed).

EN

CONTACT	DESCRIPTION
<b>13 (COR) 14</b> 	Output (potential free contact) for connecting courtesy light. 230 Vac 100 W - 24 Vac/dc 40 W (fig. 3).
<b>16(+LAM) 15 (COM)</b> 	Connection for flashing light (24 Vdc - duty cycle 50%) (fig. 2). The settings for the pre-manoeuvre flashing warning signal may be selected with parameter <i>RS</i> , while the flashing mode is set with parameter <i>7B</i> .
<b>17(+ES) 15 (COM)</b> 	Input for connecting electric lock, 12 Vdc max. 15 W (fig. 2). The function of the electric lock is determined by parameter <i>29</i> .
<b>18(+24V) 15 (COM)</b>	Power feed for external devices. See technical characteristics.
<b>20(SC) 19 (COM)</b> 	Connection for gate open indicator lamp. 24 Vdc 3 W (fig 2). The function of the indicator lamp is determined by parameter <i>AB</i> .
<b>20(SC) 19 (COM)</b> 	Photocell test connection and/or battery saving (fig. 5 and 6). The power feed for the photocell transmitters (TX) may be connected to this. Set the parameter <i>AB 02</i> to enable the test function. Each time a command is received, the control unit switches the photocells off and on to check that the contact changes state correctly. Power feeds for all external devices may be connected to reduce battery consumption (if batteries are used). Set <i>AB 03</i> or <i>AB 04</i> . <b>WARNING!</b> If contact <b>20 (SC)</b> is used for the photocell test function or battery saving function, a gate open indicator lamp cannot be connected.
<b>22(FT2) 21 (COM)</b> 	Input (N.C. or 8.2 kOhm) for connecting photocells <b>FT2</b> (fig. 4-5-6). The photocells <b>FT2</b> are configured by default with the following settings: <ul style="list-style-type: none"> <li>- <i>53 00</i> . Photocell <b>FT2</b> disabled when gate is opening.</li> <li>- <i>54 00</i> . Photocell <b>FT2</b> disabled when gate is closing.</li> <li>- <i>55 01</i> . The gate opens when an open command is received if photocell <b>FT2</b> is obstructed.</li> <li>- <i>57 00</i>. NC (normally closed) incoming contact.</li> </ul> If the photocells are not installed, jumper the terminals <b>21(COM) - 22(FT2)</b> or set the parameters <i>53 00</i> and <i>54 00</i> . <b>WARNING!</b> Use <b>R90/F4ES</b> , <b>G90/F4ES</b> or <b>T90/F4S</b> series photocells.
<b>23(FT1) 21 (COM)</b> 	Input (N.C. or 8.2 kOhm) for connecting photocells <b>FT1</b> (fig. 4-5-6). The photocells <b>FT1</b> are configured by default with the following settings: <ul style="list-style-type: none"> <li>- <i>50 00</i> . Photocell triggers only during gate closure. Photocell is ignored during gate opening.</li> <li>- <i>51 02</i> . Movement is reversed if the photocell is triggered during gate closure.</li> <li>- <i>52 01</i> . The gate opens when an open command is received if photocell <b>FT1</b> is obstructed.</li> <li>- <i>57 00</i>. NC (normally closed) incoming contact.</li> </ul> If the photocells are not installed, jumper the terminals <b>23(FT1) - 21(COM)</b> or set the parameters <i>50 00</i> and <i>51 00</i> . <b>WARNING!</b> Use <b>R90/F4ES</b> , <b>G90/F4ES</b> or <b>T90/F4S</b> series photocells.
<b>24(COS2/IN2) 26 (COM)</b> 	Input (NC or 8 kOhm) for connecting sensing edge <b>COS2</b> . The sensing edge is configured by default with the following settings: <ul style="list-style-type: none"> <li>- <i>74 00</i>. The sensing edge <b>COS2</b> (NC contact) is disabled.</li> </ul> If the sensing edge is not installed, jumper the terminals <b>24(COS2) - 26(COM)</b> or set the parameter <i>74 00</i> .

CONTACT	DESCRIPTION
<b>25(COS1) 26(COM)</b> 	Input (NC or 8 kOhm) for connecting sensing edge <b>COS1</b> (fig. 2). The sensing edge is configured by default with the following settings: – 73 03. If the sensing edge <b>COS1</b> (NC contact) is enabled, the gate always reverses. If the sensing edge is not installed, jumper the terminals <b>25(COS1) - 26(COM)</b> or set the parameter 73 00.
<b>27(ST) 26(COM)</b> 	STOP command input (N.C. or 8.2 kOhm). The current manoeuvre is arrested if the safety contact opens. <b>N.B.:</b> the controller is supplied with this contact already jumpered by ROGER TECHNOLOGY. – The contact is configured by default with the following settings: 57 00. (normally closed) incoming contact.
<b>29 (ANT) 30</b> 	Antenna connector for slot-in radio receiver board. Use RG58 if an external antenna is used; maximum recommended length: 10 m. <b>N.B.:</b> do not make joints in cable.
<b>32(ORO/IN1) 31(COM)</b> 	Clock timer contact input (N.O.). When the clock function is active, the gate opens and remains open. At the end of the programmed time set with the external device (clock), the gate closes.
<b>33(AP) 37(COM)</b> 	Open control signal input (N.O.). <b>IMPORTANT:</b> persistent activation of the opening command prevents automatic reclosure; the automatic reclosure time count is resumed when the opening command is released.
<b>34(CH) 37(COM)</b> 	Close command input (N.O.).
<b>35(PP) 37(COM)</b> 	Step by step mode command input (N.O.). The function of the control is determined by parameter R4.
<b>36(PED) 37(COM)</b> 	Partial open control signal input (N.O.). On double leaf gate automation systems, by default, the partial opening command opens LEAF 1 completely. With single leaf swing gate installations, by default, partial opening is 50% of total opening.
<b>ABSOLUTE ENCODER (SMARTY EMA)</b>	Absolute encoder installed on SMARTY Series motors (see fig. 8). During travel acquisition, the encoder reading is acquired in the completely open and completely closed positions. During normal operation, the encoder reading is acquired at each motor start, except in the case of direction inversion due to activation of the sensing edge, the obstacle detection system or the photocells, or requested by the user with a command.  <b>N.B.:</b> The absolute encoder is connected in parallel with the motor phases. Normally, the encoder will emit a short audible signal (whistle). If no audible signal is heard, the encoder may be disconnected, absent or damaged.  For <b>SMARTY REVERSIBLE:</b> the encoder is already assembled and installed in the factory by ROGER TECHNOLOGY. For <b>SMARTY IRREVERSIBLE:</b> product code <b>SMARTY/EMA</b> is available for installing the encoder on the motor. Enable the encoder with the parameter 71 01 and perform the travel acquisition procedure. <b>IMPORTANT:</b> before programming the travel, make sure you have selected the correct motor model via parameter R1. An incorrect setting will prevent the absolute encoder from working. If parameter R1 is modified with <b>SMARTY/EMA</b> installed, repeat the travel acquisition procedure
<b>RECEIVER CARD</b>	Connector for plug-in radio receiver board. The control unit has two radio remote control functions by default: – <b>PR1</b> - step mode command (modifiable with parameter 75). – <b>PR2</b> - partial opening command (modifiable with parameter 77).

CONTACT	DESCRIPTION
<b>BATTERY CHARGER B71/BCHP</b>	(Fig. 7) In the event of a mains power loss, the control unit is powered by the batteries. When battery power is used, <i>bAtt</i> is shown on the display and the flashing light flashes briefly at intervals until mains power is restored or until the battery voltage drops below the minimum permissible limit. In this case, <i>bLL</i> (Battery Low) is shown on the display and the control unit accepts no commands. If mains power is lost while the gate is moving, the gate stops and then automatically resumes the interrupted manoeuvre after 2 seconds.
<b>BATTERY KIT 2x12 Vdc 4,5 Ah (B71/BCHP/EXT)</b>	N.B: in battery power mode, a fixed delay time of 1.5 s is applied even if delay times are disabled with parameters <i>25</i> and <i>26</i> . To reduce battery consumption, the positive power feed wire of the photocell transmitters and receiver may be connected to terminal <b>SC</b> (see fig. 5-6). Set <i>AB 03</i> or <i>AB 04</i> . In this configuration, the control unit disconnects power from the accessory devices when the gate is completely open or completely closed.
Only <b>AGM</b> type	<b>WARNING!</b> the batteries must always be connected to the electronic control unit in order to charge. Periodically (at least every 6 months), check that the batteries are in good working order.
	For more information, refer to the installation manual for the <b>B71/BCHP</b> battery charger.

### 13 Safety input and command status (TEST mode)

With no currently active commands, press the TEST button and check the following:

DISPLAY	POSSIBLE CAUSE	ACTION BY SOFTWARE	PHYSICAL CORRECTIVE ACTION
<i>88 27</i>	The safety <b>STOP</b> contact is open. Incorrect setting of parameter <i>57</i> .	Check that parameter <i>57</i> is set correctly	Install a <b>STOP</b> button (NC) or jumper the <b>ST</b> contact with the <b>COM</b> contact.
<i>88 25</i>	Sensing edge <b>COS1</b> not connected or incorrectly connected.	Set the parameter <i>73 00</i> if not used or to disable.	Jumper contact <b>COS1</b> with contact <b>COM</b> , if not used or to disable
<i>88 24</i>	Sensing edge <b>COS2</b> not connected or incorrectly connected.	Set the parameter <i>74 00</i> if not used or to disable.	Jumper contact <b>COS2</b> with contact <b>COM</b> , if not used or to disable.
<i>88 23</i>	Photocell <b>FT1</b> not connected or incorrectly connected. Incorrect setting of parameter <i>57</i> .	Set the parameter <i>50 00</i> e <i>51 00</i> if not used or to disable.	Jumper contact <b>FT1</b> with contact <b>COM</b> , if not used or to disable. Check connection referring to relative connection diagram (figure 4).
<i>88 22</i>	Photocell <b>FT2</b> not connected or incorrectly connected. Incorrect setting of parameter <i>57</i> .	Set the parameter <i>53 00</i> e <i>54 00</i> if not used or to disable.	Jumper contact <b>FT2</b> with contact <b>COM</b> , if not used or to disable. Check connection referring to relative connection diagram (figure 4).
<i>PP 00</i>	If occurs with no voluntary command, the contact (N.O.) may be faulty or one of the buttons may be incorrectly connected.	-	Check <b>PP - COM</b> contacts and connections to buttons.
<i>CH 00</i>		-	Check <b>CH - COM</b> contacts and connections to buttons.
<i>AP 00</i>		-	Check <b>AP - COM</b> contacts and connections to buttons.
<i>PE 00</i>		-	Check <b>PED - COM</b> contacts and connections to buttons.
<i>Or 00</i>	If occurs with no command, the contact (N.O.) may be faulty or the timer may be incorrectly connected.	-	Check <b>ORO - COM</b> contacts. Contact must not be jumpered if not used.

**N.B:** press TEST to exit TEST mode.

We recommend troubleshooting safety device and input status errors with “corrective action by software” only.

# 14 Alarms and faults

EN

PROBLEM	ALARM	POSSIBLE CAUSE	ACTION
The gate does not open or close.	POWER LED off	No power.	Check power cable.
	POWER LED off	Fuses blown.	Replace fuse. Always disconnect from mains power before removing fuses.
	OF St	Input mains power voltage fault. Control initialisation failed.	Disconnect from mains power, wait 10 seconds then reconnect to the mains and switch on. We recommend replacing the control unit if the problem persists.
	Pr Ot	Overcurrent detected in inverter.	Press the <b>TEST</b> button twice or perform 3 command requests in succession.
	SECO	Incorrect connection between SEC1 and SEC2 of the transformer.	Swap the connection between SEC1 and SEC2.
	dA tA	Incorrect travel length values.	Press the TEST button and check the safety device/s in alarm state and the connections of the safety devices. Check that the mechanical stops of MOTOR 1 and MOTOR 2 are positioned correctly. Repeat acquisition procedure.
		Parameter 71 modified	The error message dA tA appears on the display whenever this parameter is modified. Press the PROG key until APP- appears on the display, then repeat the acquisition procedure (see chapter 9).
	Not 1	Motor 1 not connected.	Check the motor cable.
	Not 2	Motor 2 not connected.	Check the motor cable.
	FUSE	Fuse F1 blown or damaged. This message is not visible if controller is in battery power mode.	Replace fuse. Always disconnect from mains power before removing and refitting fuses.
	Example: 15 EE 21 EE	Configuration parameter error.	Set configuration value correctly and save.
	En 11	MOTOR 1 encoder not responding, absent or faulty.	Check encoder connection. Replacing the encoder is recommended if the problem persists.
	En 21	MOTOR 2 encoder not responding, absent or faulty.	Check encoder connection. Replacing the encoder is recommended if the problem persists.
	En 12	Communication error between controller and MOTOR 1 encoder.	Check connection of MOTOR 1.
	En 22	Communication error between controller and MOTOR 2 encoder.	Check connection of MOTOR 2.
	En 13	Minor malfunction of MOTOR 1 encoder.	Check connection of MOTOR 1. Check power voltage of controller.
	En 23	Minor malfunction of MOTOR 2 encoder.	Check connection of MOTOR 2. Check power voltage of controller.
	En 14	Encoder MOTOR 1 encoder magnet malfunction. Severe encoder error.	Replacing the encoder is recommended if the problem persists.
	En 24	Encoder MOTOR 2 encoder magnet malfunction. Severe encoder error.	Replacing the encoder is recommended if the problem persists.
	En 15	Position detected of MOTOR 1 incongruent with travel length.	Repeat acquisition procedure. Replacing the encoder is recommended if the problem persists.
En 25	Position detected of MOTOR 2 incongruent with travel length.	Repeat acquisition procedure. Replacing the encoder is recommended if the problem persists.	
btLO (btLO)	Flat batteries.	Wait for mains power to be restored.	

PROBLEM	ALARM	POSSIBLE CAUSE	ACTION
Acquisition procedure does not complete correctly.	<i>AP P.E</i>	TEST button pressed accidentally.	Repeat acquisition procedure.
		Safety devices in alarm state.	Press the TEST button and check the safety device/s in alarm state and the connections of the safety devices.
		Excessive voltage drop.	Repeat acquisition procedure. Check mains voltage.
Acquisition procedure does not complete correctly.	<i>AP PL</i>	Travel length error.	Move gate into completely closed position and repeat the procedure.
Remote control has limited range and does not work while automated gate is moving.	-	The radio transmission is impeded by metal structures and reinforced concrete walls.	Install the antenna.
	-	Flat batteries.	Replace the transmitter batteries.
The flashing light is not working.	-	Bulb / LED blown or flashing light wires disconnected.	Check LED circuit and/or connector wires.
With gate stops, the flashing light flashes with a regular duty cycle (1 s on / 4 s off).	<i>ASSt (ASSt)</i>	Maintenance alarm.	Perform a maintenance program. To reset the alarm, deactivate the password ( <i>CP 00</i> ) and press TEST for 5 s. The message <i>ASSt</i> is displayed, followed by the messages <i>UPdt</i> flashing for 4 seconds: to reset the alarm, hold down the TEST key until <i>donE</i> is displayed. If the TEST key is released, <i>Abre</i> appears on the display and the alarm is not reset. The manoeuvre counter resets. The number of hours <i>HD-H I</i> is stored by the control unit, and the count is reset. N.B.: when 9990 hours of manoeuvres are exceeded, the maintenance alarm is disabled entirely.
Message <i>POS</i> together with audible warning signal. (with SMARTY/EMA only)	<i>POS1 (POS1)</i>	Notification that MOTOR 1 position reading is in progress.	At start of each manoeuvre, the control unit acquires the position of MOTOR 1. If the position is not read successfully, the message <i>En11</i> is shown on the display.
	<i>POS2 (POS2)</i>	Notification that MOTOR 2 position reading is in progress.	At start of each manoeuvre, the control unit acquires the position of MOTOR 2. If the position is not read successfully, the message <i>En21</i> is shown on the display.
Gate open indicator lamp does not work.	-	Bulb blown or wires disconnected.	Check the bulb and/or wires.
Gate does not perform desired manoeuvre.	-	Motor leads crossed.	Swap two wires on terminal X-Y-Z or Z-Y-X.

**N.B.:** Press the TEST button to temporarily cancel the alarm.

The next time a command is received, the alarm reappears on the display if the problem has not been resolved.



# 15 Procedural verifications - INFO Mode

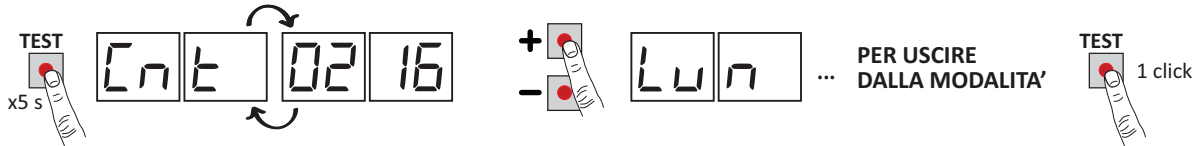

INFO mode may be used to view certain parameters measured by the **EDGE1** controller. Press and hold the TEST button for 5 seconds from the “View command signals and safety devices” mode with the motor stationary. The control unit displays the following parameters and the corresponding measured values in sequence:

Parameter	Function
<i>P3.05</i>	View for 3 s the firmware version of the control unit.
<i>Cnt 1</i> <i>Cnt 2</i>	Displays the position of MOTOR 1 / MOTOR 2, expressed in revolutions and relative to total length, at the time of the test.
<i>Lun 1</i> <i>Lun 2</i>	View total length of MOTOR 1/ MOTOR 2 programmed travel , in motor revolutions.
<i>rPM 1</i> <i>rPM 2</i>	View MOTOR 1 /MOTOR 2 speed, in revolutions per minute (rPM).
<i>AMP 1</i> <i>AMP 2</i>	View current absorption of MOTOR 1/MOTOR 2, in Amperes (e.g.: 001.1 = 1,1 A .... 016.5 = 16,5 A). If the MOTOR 1 / MOTOR 2 is stationary, the current absorption value is 0. Activate a command function to test current absorption.
<i>bUS</i>	System OK indicator. To check for overloading (e.g.: too many utilities connected to 24 V output) or if the mains voltage is too low, compare the parameters read with values indicated as follows with the motor stationary: mains voltage= 230 Vac (nominal), bUS= 37.5 mains voltage= 207 Vac (-10%), bUS= 33.6 mains voltage= 253 Vac (+10%), bUS= 41.5
<i>CNP 1</i> <i>CNP 2</i>	Display current, expressed in Amperes, used to compensate for strain detected by MOTOR 1 / MOTOR 2 due, for example, to low external temperatures (e.g.: 0 = 0 A ... 4 = +3 A). At the beginning of a manoeuvre from the completely open or completely closed position, if the control unit detects a strain higher than the value stored in its memory during the travel acquisition cycle, the controller automatically increases the current delivered to MOTOR 1 / MOTOR 2.
<i>ASC 1</i> <i>ASC 2</i>	Display current threshold, expressed in Amperes, at which the obstacle detection function (crush prevention) of MOTOR 1 / MOTOR 2 is triggered. This value is calculated automatically by the controller in relation to the settings of parameters 30, 31 and 32. For the motor to function correctly, <i>AMP</i> must always be lower than the value <i>ASC</i> .
<i>Et n 1</i> <i>Et n 2</i>	Indicates time taken by motor to detect an obstacle, as set with parameter 31/32, in seconds. E.g. 1.000 = 1 s / 0.120 = 0.12 s (120 ms). Ensure that the manoeuvre time is more than 0.3 s.
<i>AbS 1</i> <i>AbS 2</i>	MOTOR 1 / MOTOR 2 status OK indicator. In normal conditions, this value is less than 500. If the value exceeds 2000, the controller disables the motor. A value exceeding 500 indicates that the characteristics of the connection cable are inadequate for the installation or that the connection cable is too long or of inadequate cross section, or may indicate an electrical fault of the brushless motor.
<i>UP</i>	If the control unit is capable of identifying the position of the gate leaf when the test is conducted, the following is shown on the display: <i>UP</i> _ _ position known, normal operation. <i>UP</i> 1 _ LEAF 1 position unknown, position recovery in progress. <i>UP</i> _ 1 LEAF 2 position unknown, position recovery in progress. <i>UP</i> 1 2 positions of both leaves unknown, position recovery in progress.
<i>OC</i>	Indicates the state of the automation system (open/closed). <i>OC</i> <i>OP</i> automation system opening (motor active). <i>OP</i> <i>CL</i> automation system closing (motor active). <i>OP</i> - <i>O</i> automation system completely open (motor not active). <i>OP</i> - <i>C</i> automation system completely closed (motor not active).
<i>UF</i>	<i>UF</i> <i>U</i> mains voltage too low or overload. <i>UF</i> <i>H</i> motors overcurrent.
<i>HOUr</i>	Displays the number of hours remaining before the maintenance alarm is activated. The number is preceded by a - (minus) symbol. If the number of remaining hours is a four figure value, the minus symbol (-) is replaced by a point. Example: -1234 hours remaining until maintenance alarm = .1234 • Pressing ↓ (DOWN arrow): view number of hours of last maintenance service. The first service is indicated as 0.0.0.0 . • Pressing ↑ (UP arrow): return to remaining hours display.
<i>bLoc</i>	Displays 00= motor brake not active; 10=brake active on motor 1; 02=brake active on motor 2; 12= brake active on both motors; -- -- = brake function not available.

- If only one motor is connected to the control unit, the parameters relative to “MOTOR 1” only are displayed.
- Use the + / - buttons to scroll through the parameters. When the last parameter in the sequence is reached, press the - button to return through the previous parameters.
- In INFO mode, the automation system may be activated to test operation in real time.



- The two motors may be controlled independently in OPERATOR PRESENT mode, ignoring the error "dRtR" and bypassing the safety devices installed (photocells, sensing edges and STOP button) with the exception of the obstacle detection system. MOTOR 1 is controllable when the messages:  $\text{Cnt 1}$ ,  $rP1$ ,  $R1P1$  and  $Rb5 1$  appear on the display. MOTOR 2 is controllable when the messages  $\text{Cnt 2}$ ,  $rP2$ ,  $R2P2$  and  $Rb5 2$  appear on the display.
  - THE MOTOR in question is activated on opening by pressing the ▲ "UP" key and on closure by pressing the ▼ "DOWN ARROW" key.
  - For safety, the open and close functions are only available in continuous control (operator present) mode: press the button, release within 1 second and then press and hold. The motor stops as soon as the button is released.

**WARNING: during the check, the motor revolution count (position) is updated but the gate leaf alignment control function may cause problems. Before exiting INFO, make sure that the gate leaves are correctly aligned.**
- Press and hold the TEST button for a few seconds to exit INFO mode.

## 16 Mechanical release

In the event of power failure, the gate may be unlocked by following the instructions given in the use and maintenance manual of the automation system. On receiving the first command signal after mains power is restored, the control unit starts an opening manoeuvre in position recovery mode (see chapter 17-18). For **SMARTY 5R / SMARTY 7R**: in the event of an electricity failure or  $E400$ , the gate can be manually opened and closed without releasing it, with the motor idle.

The **SMARTY/EMA** absolute encoder (installed as standard on **SMARTY REVERSIBLE** units and optional on **SMARTY IRREVERSIBLE** units) allows the controller to reacquire the position immediately after each new command signal received.

## 17 Position recovery WITHOUT the absolute encoder

On receiving the first command signal after a power failure or after detecting an obstacle in the same position three consecutive times, the control unit starts a manoeuvre in position recovery mode.

On receiving a command signal, the gate starts a manoeuvre at low speed. The flashing light flashes with a different duty cycle than normal (3 s on, 1.5 s off).

The control unit recovers the installation data during this procedure. **Warning:** Do not use any controls until the gate has performed a complete manoeuvre for both leaves.

If the gate is released in the completely open or completely closed position with the control unit powered, always return the gate leaves into their original positions before locking the gate release again. The gate will resume normal operation on receipt of the first control command.

**WARNING:** Releasing the gate in an intermediate position is not recommended, as it may cause the leaf position parameters to be lost (see parameters  $\text{Cnt 1}$  /  $\text{Cnt 2}$  in INFO mode). In this case, a position recovery procedure is necessary.

## 18 Position recovery WITH the absolute encoder (SMARTY range only)

Upon receipt of the first command after a power failure or after the gate is unlocked, the controller uses the absolute encoder to reacquire the position of the gate leaf immediately.

If the control unit detects that the gate leaves are not positioned correctly, it corrects the error automatically. For example: if the control unit receives a close request but the gate leaves cannot close, the unit executes a complete open cycle and then closes the leaves after 1 s (even if automatic closure is not enabled) to restore the correct alignment.

**Warning:** Do not use any controls until the gate has performed a complete manoeuvre for both leaves.

## 19 Initial testing

- Turn on the power supply.
- Check that the automation system motors rotate in the correct direction. If the leaves do not move correctly, swap any two of the wires on the X-Y-Z terminal.
- Check that all connected controls are working correctly.
- Check travel and deceleration.
- Check that the impact force is correct, in compliance with EN 12453 and EN12445.
- Check that the safety devices are activated correctly.
- If the photocell test is enabled, check it is working properly by obscuring the photocells and giving a command: the gate leaves must not move.
- If the battery kit is installed, disconnect from mains and check that the batteries are working.
- Disconnect from mains power and disconnect the batteries (if used), then reconnect. Check the correct completion of the position recovery phase when opening and when closing.
- For SMARTY Series automation systems with absolute encoder installed, disconnect and reconnect power.

Perform a manoeuvre with the controls and check that the speed and deceleration values are correct. The position recovery manoeuvre is not performed.

- If **54**  (SMARTY REVERSIBLE only), check that the gate leafs are locked when the motors are stopped.

## 20 Maintenance

---

Perform scheduled maintenance every 6 months.

Check cleanliness and function.

If the unit contains dirt, moisture, insects or other foreign matter, disconnect from mains power and clean the board and the housing.

Repeat the initial installation test procedure after cleaning.

If any corrosion is found on the printed circuit board, evaluate if it is necessary to replace the board itself.

Check that the battery is in good working order.

Check the **SMARTY 5R** and **7R** motors are braking properly.

## 21 Disposal

---



The product may only be uninstalled by qualified technical personnel, following suitable procedures for removing the product correctly and safely. This product consists of numerous different materials. Some of these materials may be recycled, while others must be disposed of correctly at the specific recycling or waste management facilities indicated by local legislation applicable for this category of product.

Do not dispose of this product as domestic refuse. Observe local legislation for differentiated refuse collection, or hand the product over to the vendor when purchasing an equivalent new product.

Local legislation may envisage severe fines for the incorrect disposal of this product.

**Warning!** Some parts of this product may contain substances that are harmful to the environment or dangerous and which may cause damage to the environment or health risks if disposed of incorrectly.

## 22 Additional information and contact details

---

ROGER TECHNOLOGY is the exclusive proprietor holder of all rights regarding this publication.

ROGER TECHNOLOGY reserves the right to implement any modifications without prior notification. Copying, scanning or any alterations to this document are prohibited without express prior authorised from by ROGER TECHNOLOGY.

### **ROGER TECHNOLOGY CUSTOMER SERVICE:**

business hours: Monday to Friday  
08:00 to 12:00 - 13:30 to 17:30

Telephone no: +39 041 5937023

E-mail: [service@rogertechnology.it](mailto:service@rogertechnology.it)

Skype: service\_rogertechnology

To request support for any problems or for any other queries regarding the automation system, please compile the online form "REPAIRS" in the 'Self Service' area of our website [www.rogertechnology.com/B2B](http://www.rogertechnology.com/B2B).

## 23 Declaration of Conformity

---

I the undersigned, as acting legal representative of the manufacturer

**Roger Technology - Via Botticelli 8, 31021 Bonisiolo di Mogliano V.to (TV)**

hereby DECLARE that the appliance described below:

Description: Controller unit for automatic gates

Model: **EDGE1**

Is conformant with the legal requisites of the following directives:

- 2006/42/EC

- 2004/108 /EU

- 2011/65/EC

and that all the standards and/or technical requirements indicated as follows have been applied:

EN 61000-6-3

EN 61000-6-2

Last two figures of year in which marking was applied **CE 17**.

Place: Mogliano V.to

Date: 01-03-2017

Signature