

IS161 Rev.03 02/09/2019

BIONIK4

Barriera automatica Brushless
Automatic barrier Brushless
Automatisierung für Schranke Brushless
Barrière automatique Brushless
Barrera automática Brushless
Barreira automática Brushless



IT - Istruzioni ed avvertenze per l'installatore

EN - Instruction and warnings for the installer

DE - Anleitungen und Hinweise für den Installateur

FR - Instructions et avertissements pour l'installateur

ES - Instrucciones y advertencias para el instalador

PT - Instruções e avisos para o instalador

1	Avvertenze generali	3
2	Dichiarazione di conformità	3
3	Destinazione d'uso	3
4	Limiti di impiego	4
5	Descrizione del prodotto	4
6	Dimensioni	4
7	Contenuto dell'imballo	4
8	Caratteristiche tecniche	5
9	Installazione tipo	5
10	Riferimenti e accessori	6
11	Installazione	7
11.1	Verifiche preliminari	7
11.2	Installazione piastra di base	7
11.3	Installazione barriera	7
11.4	Selezione senso di apertura	9
11.5	Installazione supporto e asta	10
12	Installazione e regolazione della molla	11
12.1	Scelta della molla	12
13	Regolazione fermo meccanico	13
14	Collegamento fotocellule	13
15	Collegamenti elettrici	14
16	Installazione kit batterie (opzionali)	14
17	Installazione lampeggiante a led bi/bled	15
18	Piano di manutenzione	16
19	Smaltimento	16
20	Informazioni aggiuntive e contatti	16
21	Operazione di sblocco / blocco	16

1	General safety precautions	17
2	Declaration of conformity	17
3	Intended use	17
4	Limitations use	18
5	Description of the product	18
6	Dimensions	18
7	Package content	18
8	Technical characteristics	19
9	Typical installation	19
10	References and accessories	20
11	Installation	21
11.1	Preliminary checks	21
11.2	Installing base plate	21
11.3	Installing the barrier	21
11.4	Selecting direction of aperture	23
11.5	Support and boom installation	24
12	Installing and adjusting the spring	25
12.1	Spring selection	26
13	Adjusting the mechanical stop	27
14	Connecting photocells	27
15	Electrical connections	28
16	Installing the battery kit (optional)	28
17	Installing the bi/bled led flashing light	29
18	Maintenance	30
19	Disposal	30
20	Additional information and contact	30
21	Release and lock procedure	30

1	Allgemeine sicherheitshinweise	31
2	Konformitätserklärung	31
3	Nutzungsbedingungen	31
4	Gebrauchsbegrenzung	32
5	Beschreibung des produkts	32
6	Abmessungen	32
7	Inhalt der verpackung	32
8	Technische daten	33
9	Typische installation	33
10	Hinweise und zubehör	34
11	Installation	35
11.1	Vorab-prüfungen	35
11.2	Installation der grundplatte	35
11.3	Installation der schranke	35
11.4	Wahl der öffnungsrichtung	37
11.5	Installation von halterung und schlagbaum	38
12	Installation und einstellung der feder	39
12.1	Wahl der federn	40
13	Einstellung mechanischer feststeller	41
14	Anschluss der lichtschranken	41
15	Elektrische anschlüsse	42
16	Installation akkusatz (optional)	42
17	Installation led-blinkleuchte bi/bled	43
18	Wartungsplan	44
19	Entsorgung	44
20	Zusätzliche informationen und kontakte	44
21	Entriegelung und verriegelung	44

1	Consignes générales de sécurité	45
2	Déclaration de conformité	45
3	Destination d'utilisation	45
4	Limites d'emploi	46
5	Description du produit	46
6	Dimensions	46
7	Contenu de l'emballage	46
8	Caractéristiques techniques	47
9	Installation type	47
10	References et accessoires	48
11	Installation	49
11.1	Vérifications préliminaires	49
11.2	Installation de la plaque de base	49
11.3	Installation de la barrière	49
11.4	Sélection du sens d'ouverture	51
11.5	Installation support et barre	52
12	Installation et réglage du ressort	53
12.1	Choix des ressorts	54
13	Réglage de la butée mécanique	55
14	Raccordement des photocellules	55
15	Raccordements électriques	56
16	Installation du kit batteries (en option)	56
17	Installation du flash clignotant à led bi/bled	57
18	Plan de maintenance	58
19	Élimination	58
20	Informations complémentaires et contacts	58
21	Opérations de déblocage et blocage	58

1	Advertencias generales	59
2	Declaración de conformidad	59
3	Uso previsto	59
4	Límites de uso	60
5	Descripción del producto	60
6	Dimensiones	60
7	Contenido del embalaje	60
8	Características técnicas	61
9	Instalación básica	61
10	Referencias y accesorios	62
11	Instalación	63
11.1	Controles preliminares	63
11.2	Instalación de la placa de base	63
11.3	Instalación de la barrera	63
11.4	Selección del sentido de apertura	65
11.5	Instalación del soporte y del asta	66
12	Instalación y ajuste del muelle	67
12.1	Cómo elegir los muelles	68
13	Ajuste del tope mecánico	69
14	Conexión de las fotocélulas	69
15	Conexiones eléctricas	70
16	Instalación del kit de baterías (opcional)	70
17	Instalación del intermitente de led bi/bled	71
18	Plan de mantenimiento	72
19	Eliminación	72
20	Información adicional y contactos	72
21	Operaciones de desbloqueo y bloqueo	72

1	Advertências gerais	73
2	Declaração de conformidade	73
3	Destino de uso	73
4	Limites de emprego	74
5	Descrição do produto	74
6	Dimensões	74
7	Conteúdo da embalagem	74
8	Características técnicas	75
9	Instalação do tipo	75
10	Referência e acessórios	76
11	Instalação	77
11.1	Verificações preliminares	77
11.2	Instalação da chapa de base	77
11.3	Instalação da barreira	77
11.4	Seleção do sentido de abertura	79
11.5	Instalação de suporte e haste	80
12	Instalação e ajuste da mola	81
12.1	Escolha das molas	82
13	Ajuste do retentor mecânico	83
14	Ligação das fotocélulas	83
15	Ligações elétricas	84
16	Instalação de kits de baterias (opcionais)	84
17	Instalação do pisca de led bi/bled	85
18	Plano de manutenção	86
19	Descarte	86
20	Informações adicionais e contatos	86
21	Operações de libertação e bloqueio	86

1 GENERAL SAFETY PRECAUTIONS



Failure to respect the information given in this manual may cause personal injury or damage to the device.

This installation manual is intended for qualified personnel only.

ROGER TECHNOLOGY cannot be held responsible for any damage or injury due to improper use or any use other than the intended usage indicated in this manual.

Installation, electrical connections and adjustments must be performed by qualified personnel, in accordance with best practices and in compliance with applicable regulations.

Read the instructions carefully before installing the product. Bad installation could be dangerous.

Before installing the product, make sure it is in perfect condition: if in doubt, do not use the equipment and contact qualified personnel only.

Do not install the product in explosive areas and atmospheres: the presence of inflammable gas or fumes represents a serious safety hazard.

Before installing the motorisation device, make all the necessary structural modifications to create safety clearance and to guard or isolate all the crushing, shearing, trapping and general hazardous areas.

Make sure the existing structure is up to standard in terms of strength and stability.

ROGER TECHNOLOGY is not responsible for failure to observe Good Working Methods when building the frames to be motorised, or for any deformation during use.

The safety devices (photocells, safety edges, emergency stops, etc.) must be installed taking into account: applicable laws and directives, Good Working Methods, installation premises, system operating logic and the forces developed by the motorised door or gate.

The safety devices must protect against crushing, cutting, trapping and general danger areas of the motorised door or gate.

The European standards EN 12453 and EN 12445 define the minimum safety requirements for the operation of automatic doors and gates. In particular, these standards require the use of force limiting and safety devices (sensing ground plates, photocell barriers, operator detection function etc.) intended to detect persons or objects in the operating area and prevent collisions in all circumstances.

Where the safety of the installation is based on an impact force limiting system, it is necessary to verify that the characteristics and performance of the automation system are compliant with the requisites of applicable standards and legislation.

The installer is required to measure impact forces and programme the control unit with appropriate speed and torque values to ensure that the door or gate remains within the limits defined by the standards EN 12453 and EN 12445.

ROGER TECHNOLOGY declines all responsibility if component parts not compatible with safe and correct operation are fitted.

Display the signs required by law to identify hazardous areas.

Each installation must bear a visible indication of the data identifying the motorised door or gate.

An omnipolar disconnection switch with a contact opening distance of at least 3mm must be fitted on the mains supply.

Make sure that upline from the mains power supply there is a residual current circuit breaker that trips at no more than 0.03A and overcurrent cutout upstream of the electrical system in accordance with best practices and in compliance with applicable regulations.

When requested, connect the automation to an effective earthing system (⊕) that complies with current safety standards.

During installation, maintenance and repair operations, cut off the power supply before opening the cover to access the electrical parts.

The electronic parts must be handled using earthed antistatic conductive arms.

Only use original spare parts for repairing or replacing products.

The installer must supply all information concerning the automatic, manual and emergency operation of the motorised door or gate, and must provide the user with the operating instructions.

The packaging materials (plastic, polystyrene, etc.) should not be discarded in the environment or left within reach of children, as they are a potential source of danger.

Dispose of and recycle the packing components in accordance with the standards in force.

These instructions must be kept and forwarded to all possible future user of the system.

2 DECLARATION OF CONFORMITY

I the undersigned, as acting legal representative of the manufacturer:

Roger Technology - Via Botticelli 8, 31021 Bonisiolo di Mogliano V.to (TV)

hereby DECLARE that the appliance described hereafter:

Description: Automatic barrier

Model: BIONIK4 serie

Is conformant with the legal requisites of the following directives:

- Directive **2006/42/EC** (Machinery Directive) and subsequent amendments;
- Directive **2014/35/EU** (Low Voltage Directive) and subsequent amendments;
- Directive **2011/65/EC** (RoHS Directive) and subsequent amendments;
- Directive **89/106/CEE** CPD Directive) and subsequent amendments;

and that all the standards and/or technical requirements indicated as follows have been applied:

EN 61000-6-3

EN 61000-6-2

EN 13241-1

Last two figures of year in which marking was applied **CE** 17.

Place: Mogliano V.to

Date: 21-04-2017

Signature

3 INTENDED USE

The BIONIK4 automated barrier is specifically conceived for installations in private or public car parks, in residential, commercial or industrial areas or in high traffic zones. This product may only be used for its expressly intended purpose. Any other usage is prohibited.

ROGER TECHNOLOGY cannot be held directly or indirectly responsible for any damage resulting from incorrect, inappropriate or unreasonable usage of this product.

4 LIMITATIONS USE

BIONIK4 barriers are suitable for CONTINUOUS operation and may be used with booms up to 4 metres in length.

5 DESCRIPTION OF THE PRODUCT

BI/004	36V DC BIONIK4 BRUSHLESS barrier for booms up to 3 or 4 metre, with control unit and on-board native encoder, complete with a fastening base with tie rods and screws and boom fastening flanges.
BI/004/115	36V DC BIONIK4 BRUSHLESS barrier for booms up to 3 or 4 metre, with control unit and on-board native encoder, complete with a fastening base with tie rods and screws and boom fastening flanges. For 115 V line power supplies.

6 DIMENSIONS



All measurements are expressed in mm unless otherwise indicated.

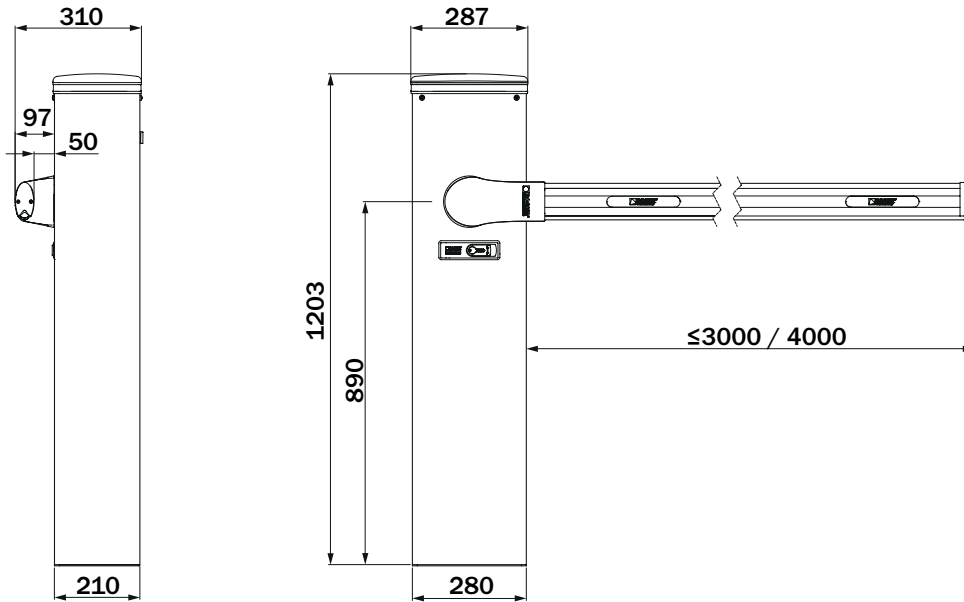

7 PACKAGE CONTENT

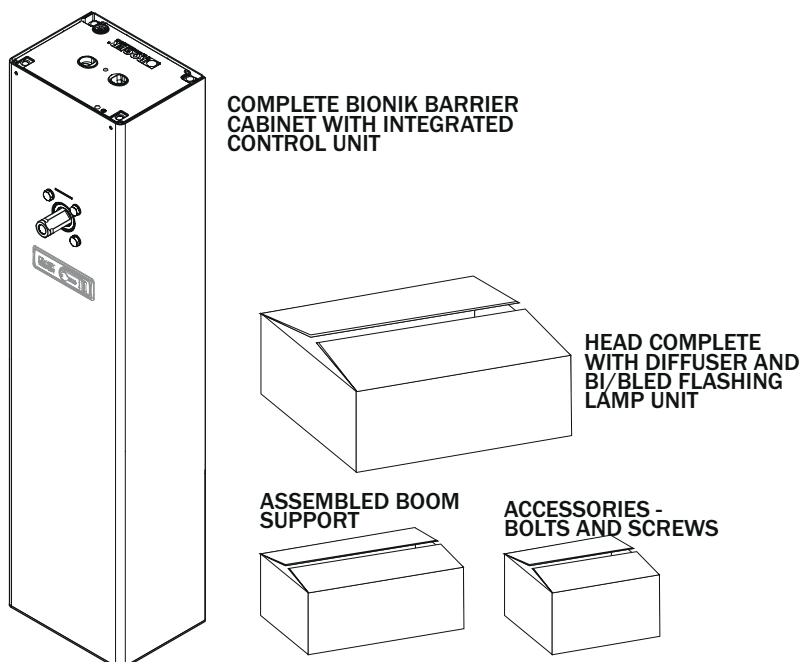

8 TECHNICAL CHARACTERISTICS

	BI/004	BI/004/115
POWER SUPPLY	230 Vac - 50 Hz ±10%	115 Vac - 60 Hz ±10%
MOTOR POWER SUPPLY	36 Vdc	36 Vdc
POWER CONSUMPTION	from 0 to 15 A	from 0 to 15 A
POWER MOTOR	220 W	220 W
TORQUE	from 0 to 200 Nm	from 0 to 200 Nm
OPEN / CLOSE TIME 90 ° (booms up to 3 m)	from 2 to 6 sec	from 2 to 6 sec
OPEN / CLOSE TIME 90 ° (booms up to 4 m)	from 3 to 6 sec	from 3 to 6 sec
CONTROL SYSTEM	ABSOLUTE ENCODER DIGITAL	ABSOLUTE ENCODER DIGITAL
USE FREQUENCY	CONTINUOUS	CONTINUOUS
OPERATING CYCLES PER DAY (OPENING/CLOSING - 24 HOURS NO STOP)	5000	5000
GRADE OF PROTECTION	IP54	IP54
OPERATING TEMPERATURE	-20°C +55°C	-20°C +55°C
CONTROL UNIT (INTEGRATED) 36 Vdc	CTRL (since version FW r3.25)	CTRL (since version FW r3.25)
ACCESSORIES POWER SUPPLY	24 Vdc	24 Vdc
BOOM	up to 4 metres	up to 4 metres
EMERGENCY BATTERY	OPTIONAL	OPTIONAL
RELEASE SYSTEM	KEY WITH A STANDARD CYLINDER	KEY WITH A STANDARD CYLINDER

9 TYPICAL INSTALLATION

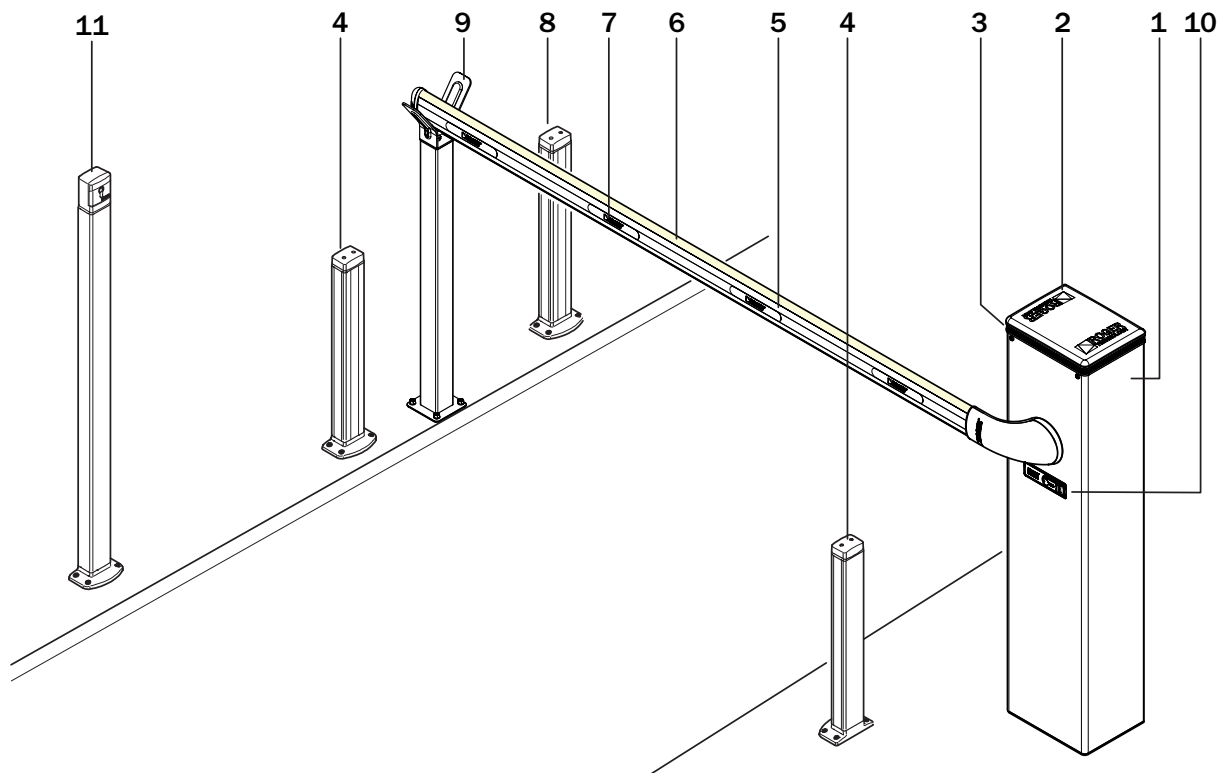

1	Automatic Barrier BIONIK4 serie
2	Integrated control unit
3	Flashing lights
4	External Photocell
5	Boom with shockproof rubber
6	Strip led

7	Reflective sticker
8	Internal Photocell
9	Fixed end rest for boom complete with a shock-resistant rubber mechanical stop
10	Release system
11	Key or keypad release switch

10 REFERENCES AND ACCESSORIES

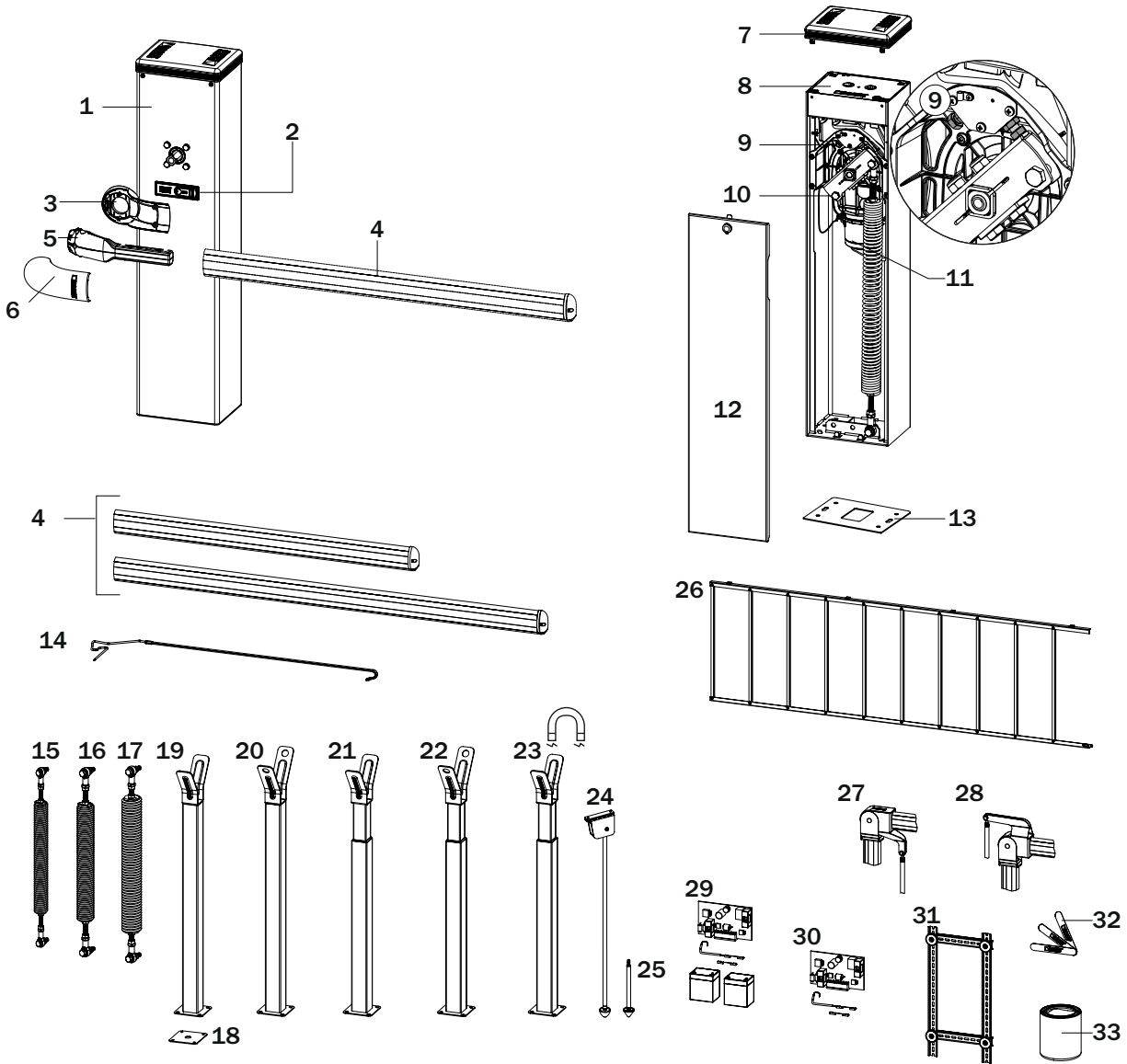

Code	Description
1	BI/004 BI/004/115 Barrier unit cabinet, in carbon steel with anti-corrosion treatment and painted.
2	Key release with a standard lock RL670 Key release with DIN cylinder (OPTIONAL)
3	Boom support arm rear cover
4	BA/68/3 Elliptical boom up to 3 m, in white painted aluminium with slot cover profiles and shock-resistant rubber. BA/68/4 Elliptical boom up to 4 m, in white painted aluminium with slot cover profiles and shock-resistant rubber.
5	Boom support arm in die-cast aluminium.
6	Boom support arm front cover.
7	Head in die-cast aluminium with anti-corrosion treatment and painted, complete with diffuser in transparent polycarbonate and BI/BLED led lights.
8	CTRL Controller unit
9	Gate open/close mechanical stop
10	Steel spring fastening linkage lever
11	Gear motor complete with brushless motor and absolute encoder
12	Corrosion-proof, painted steel inspection hatch.
13	KT240 Galvanised base plate for barrier fastening.
14	BI/ALED4C 4 m LED strip.
15	SP/48/01 Green Ø48 spring (for booms and accessories, see chap. 12).
16	SP/61/01 Blue Ø61 spring (for booms and accessories, see chap. 12).

Code	Description
17	SP/72/01 Red Ø72 spring (for booms and accessories, see chap. 12)
18	KT231 Fixed end rest fastening plate.
19	BAFS/01 Fixed end rest, non-adjustable, with rubber buffer.
20	BAFS/03 Fixed end rest with rubber, non-adjustable, with holes for a latch chain and rubber buffer.
21	BAFS/02 Fixed end rest with rubber, adjustable, telescopic with rubber buffer.
22	BAFS/04 Fixed end rest with rubber, adjustable, telescopic with holes for a latch chain and rubber buffer.
23	BAFS/05 Fixed end rest with rubber, adjustable, telescopic with rubber buffer and integrated magnet.
24	BAMS/01 Hinged end rest for booms.
25	BAMS/01/EXT Extension for hinged end rest
26	BARK/02 Drop skirt in painted aluminium. L = 2 m.
27	SND/BA/68/DW Joint with 90° pivot point with lower tie-rod
28	SND/BA/68/UP Joint with 90° pivot point with upper tie-rod
29	BI/BAT/KIT Emergency battery kit complete with battery charger and wiring (optional).
30	BI/BCHP Battery charge board complete with wiring (optional)
31	KT239 DIN bar
32	R99/BASB20 Package of 20 refractive adhesive strips for the boom. R99/BASB40 Package of 40 refractive adhesive strips for the boom.
33	RS/GR1/100 Lithium grease (EP LITIO).

11 INSTALLATION

11.1 Preliminary checks

- Check that the material received is in good condition and suitable for the application.
- Check that the operating limits of the product are not exceeded.
- Check that the site chosen for installation meets the overall space requirements of the product and that there are no obstacles hindering open or close manoeuvres.
- Check the concrete base for the barrier installation. The base must be cast in accordance with proper working practices, perfectly level and clean.

11.2 Installing base plate

The illustrations herein are indicative only. The space necessary for fastening the automation system and the accessories may vary depending on the overall dimensions of the installation. The installer is responsible for determining the most suitable solution.

- Excavate a foundation pit measuring 1m x 1m x 0.4 m and fill with concrete reinforced with steel mesh.
 - Fasten the 4 anchor ties to the plate (fig. 1). N.B.: the bottom nut must be tightened to the end of the thread on the screw so that the length Z is at least 40 mm.
 - Sink the base plate with the anchors in the centre of the foundation pit, so that the surface is flush with the concrete and perfectly level. The corrugated cable conduits must protrude by a few centimetres from the centre of the plate.
- PAY ATTENTION** to the installation direction of the plate. See the detailed view in fig. 2. The inspection side must be accessible from inside the home / shop / business.
- Installation on existing surfaces. Place the base plate on the surface and trace the positions of the fastener points. Drill the surface and fit 4 expansion anchor bolts (purchased separately).

11.3 Installing the barrier

N.B.: the barrier is configured by default for installation on the right hand side (viewed from the inspection hatch).

- Undo and remove the washers and nuts from the anchors on the base plate (fig. 3).
- Open the inspection hatch, turning the key clockwise 90° (fig. 4) and remove it.
- Place the cabinet on the plate. The anchors on the base plate must fit through the four slots.
- Fit the washers and nuts removed previously. Move the cabinet as necessary in the slots to adjust the position of the barrier correctly.
- Tighten the nuts securely (fig. 6).

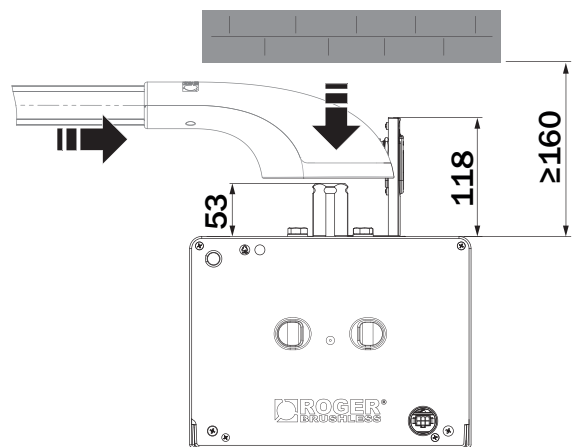
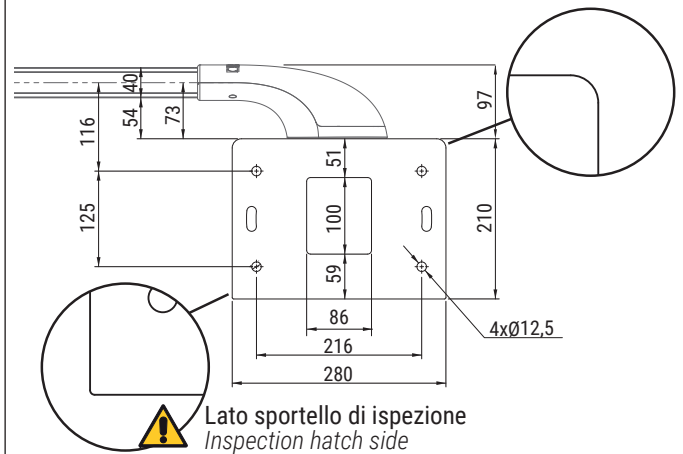
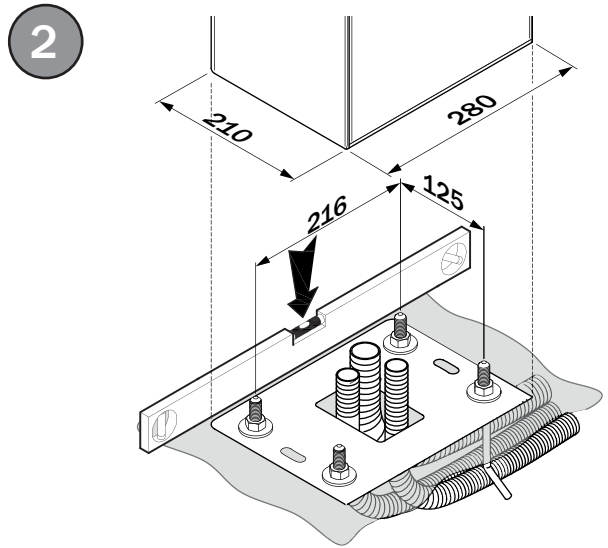
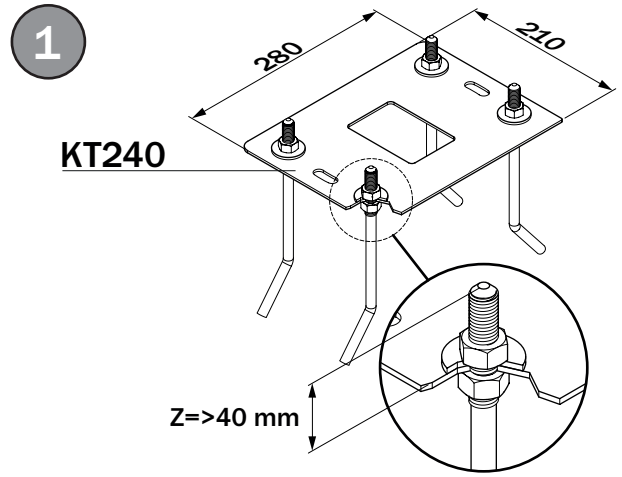

3

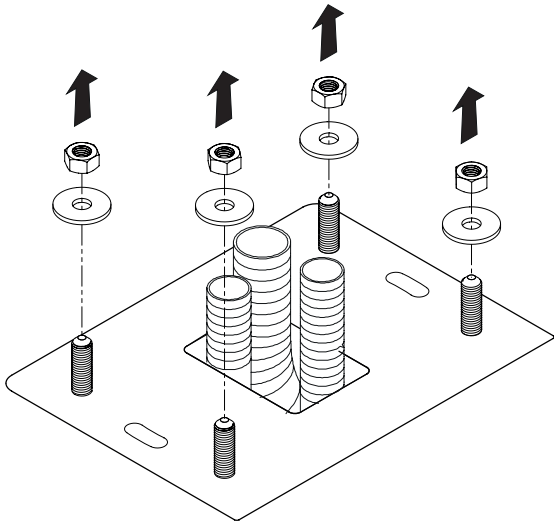

4

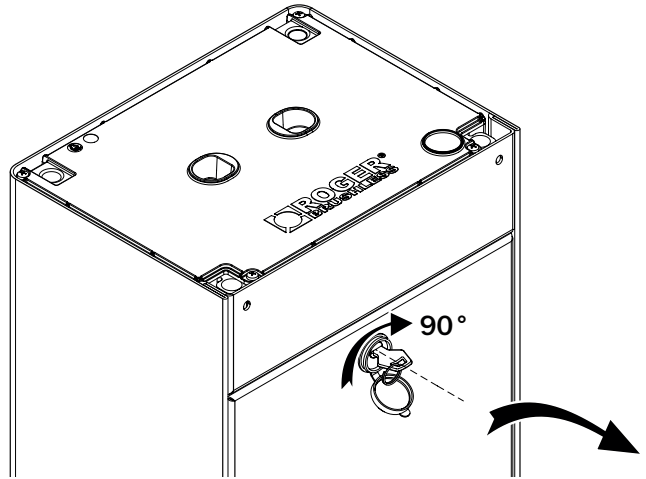

5

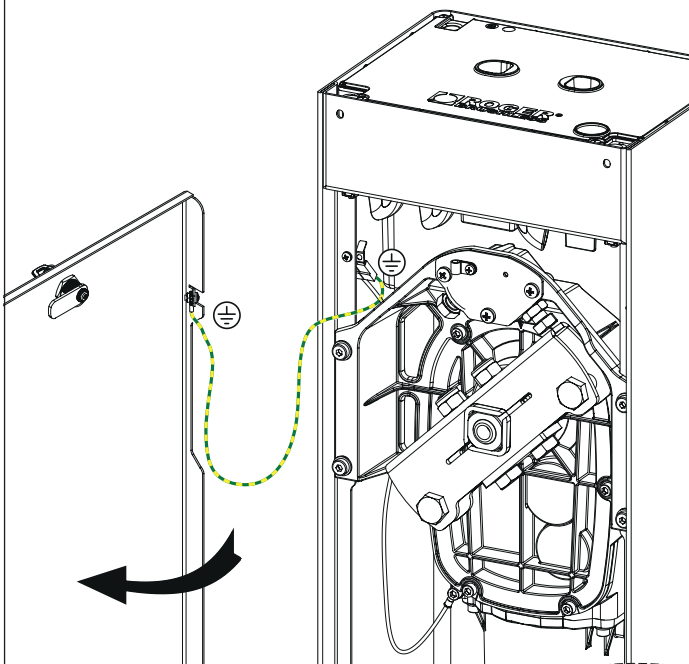

6

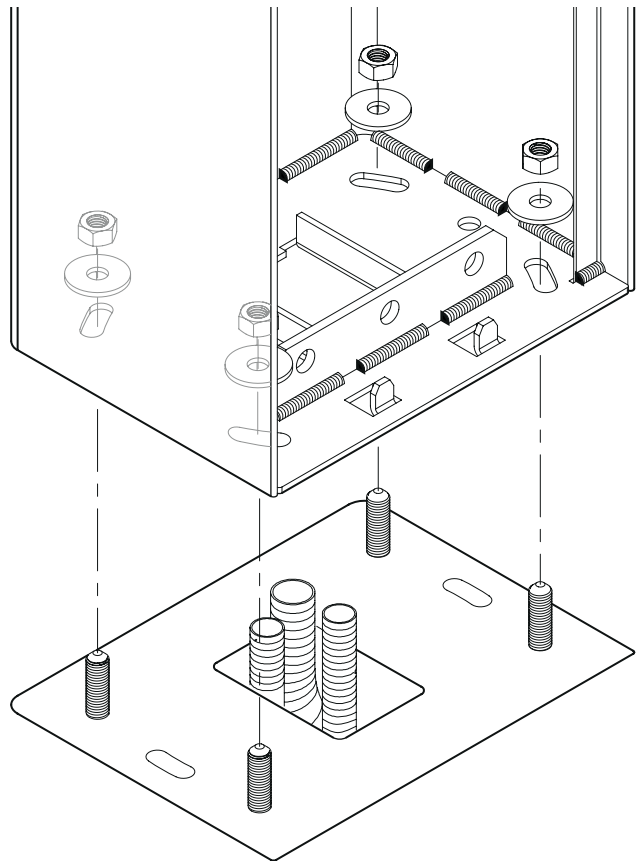

11.4 Selecting direction of aperture

i BIONIK4 barriers are configured by default for installation on the right hand side (seen from the inspection hatch side).



Whenever corrective actions are carried out, pay the utmost attention when releasing, locking or moving the internal mechanical parts. These operations could be hazardous for the installer.

For left hand installations:

- Unlock the barrier (see chapter 21).
- Turn the linkage lever as shown in figure.
- Move the mechanical stop.
- Lock the barrier (see chapter 21).

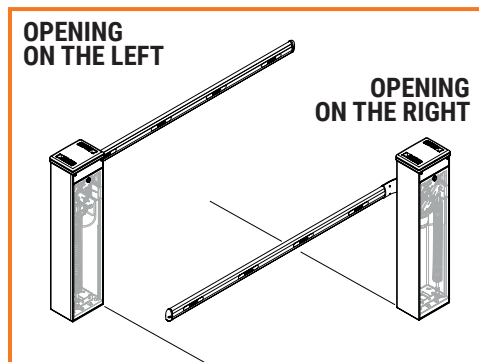

7

BARRIER INSTALLED ON THE RIGHT (SEEN FROM THE INSPECTION HATCH SIDE) AND THE BOOM OPENING/CLOSURE GATE ON THE LEFT

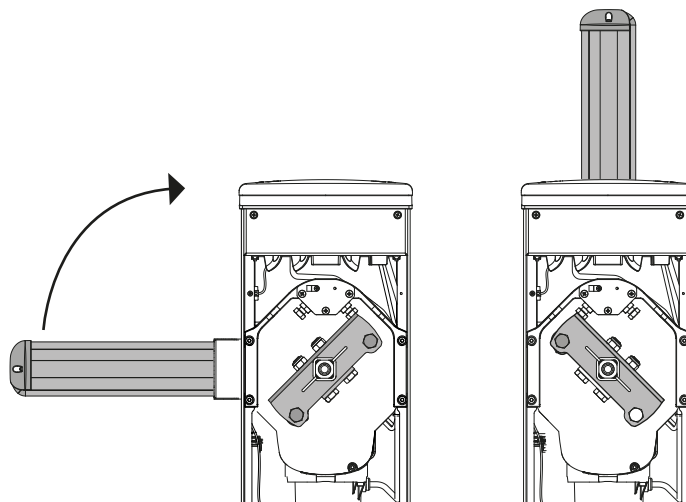

BARRIER INSTALLED ON THE LEFT (SEEN FROM THE INSPECTION HATCH SIDE) AND THE BOOM OPENING/CLOSURE GATE ON THE RIGHT

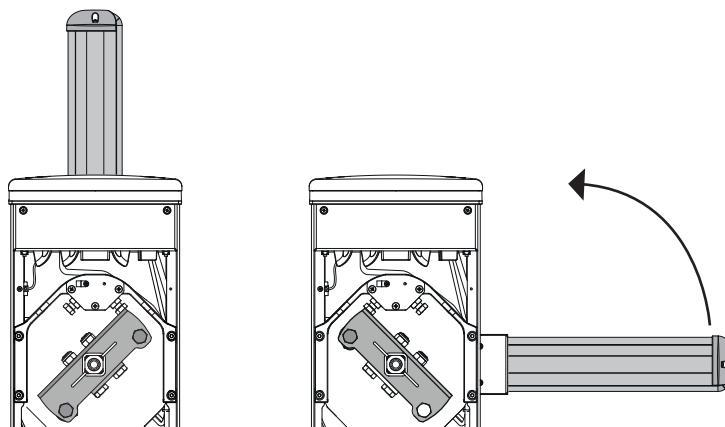

11.5 Support and boom installation

1. Unlock the barrier (see chapter 21).
2. Based on the opening direction of the barrier (fig. 7), turn the linkage lever until reaching the stop on the mechanical limit switch (fig. 7), in the position in which it is possible to install the boom horizontally.
3. Lock the barrier.
4. Open the boom support cover [A] by unscrewing the self-tapping screws TCC 4.2x19 [B].
5. Loosen the screws [E1] and insert the boom support [C] on the drive shaft [D] making sure that there is a maximum distance of 1 mm between the support and the barrier cabinet, as shown in the detailed view.
6. Fasten the support with the TCEI M8x35 screws [E1], [E2] and [E3] tightening them securely.
7. Fasten the rear cover with the provided self-tapping screws [F] TCC 4.2x19.
8. Unscrew the screws [G] TCC 4.2x13 and remove the cap [H].
9. Unscrew the screws [I] TCC 2.9x19. Remove the support [L], shock-resistant rubber [M] and the profile [N] at least 200 mm.
10. Insert the boom [O] in the support [C] and fasten it with the provided screws TCEI M8x20 [P] (complete with washers).
11. Reposition the profile [N], the shock-resistant rubber [M] and the plastic support [L] and fasten them with the screws [I] TCC 2.9x19.
12. Fasten the cap [H] with the screws [G] TCC 4.2x13.
13. Fasten the plastic support cover [A] with the self-tapping screws TCC 4.2x19 [B].

8

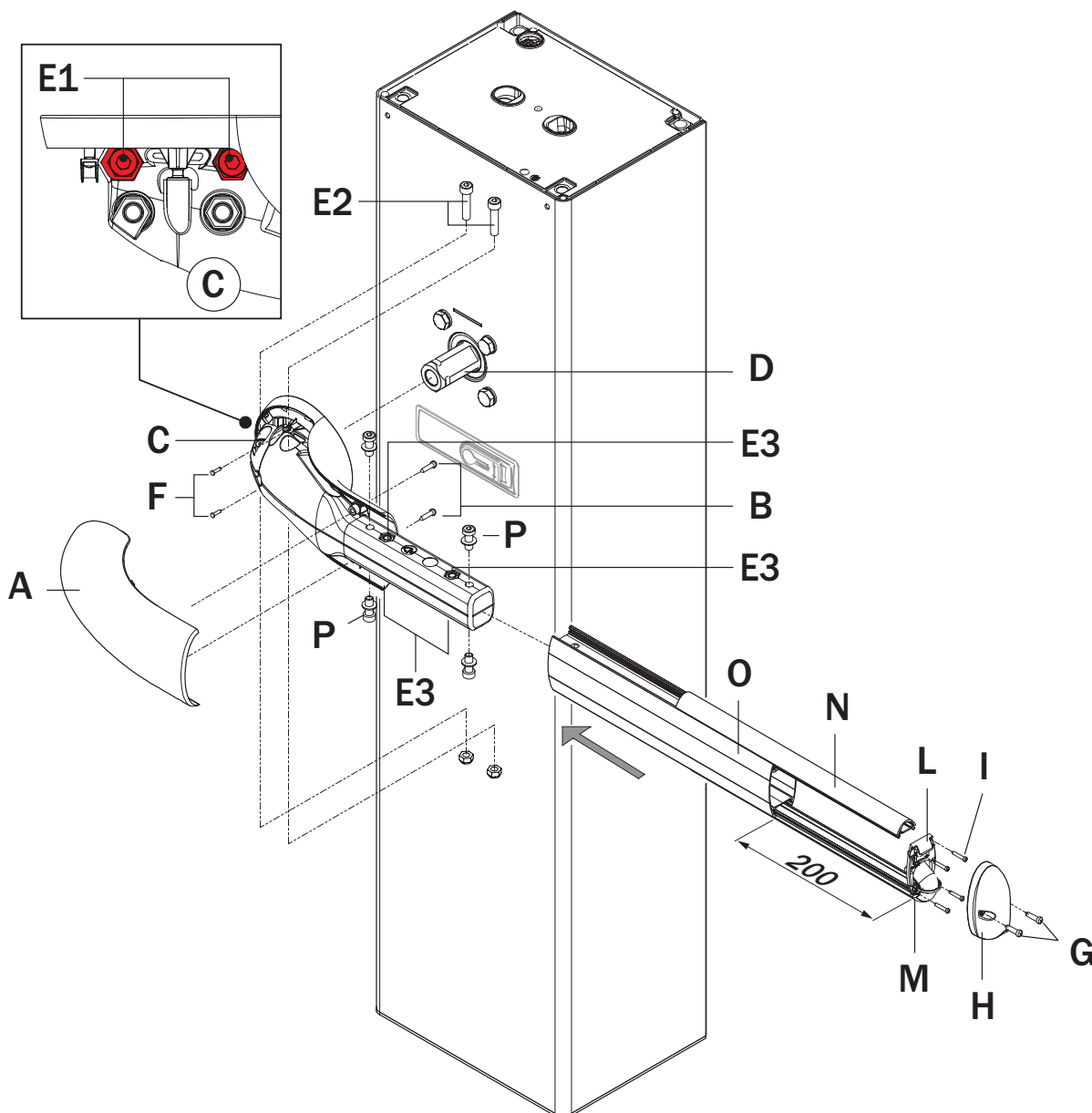
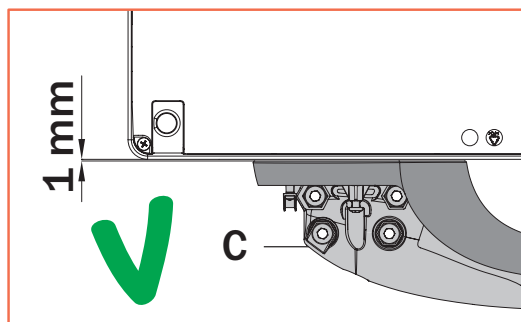
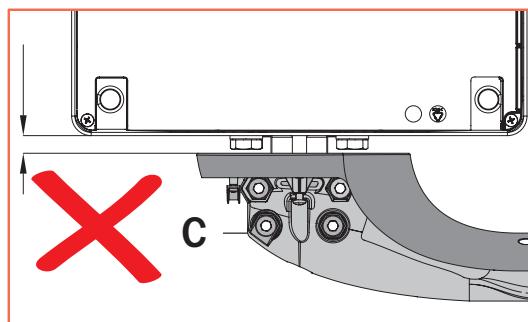





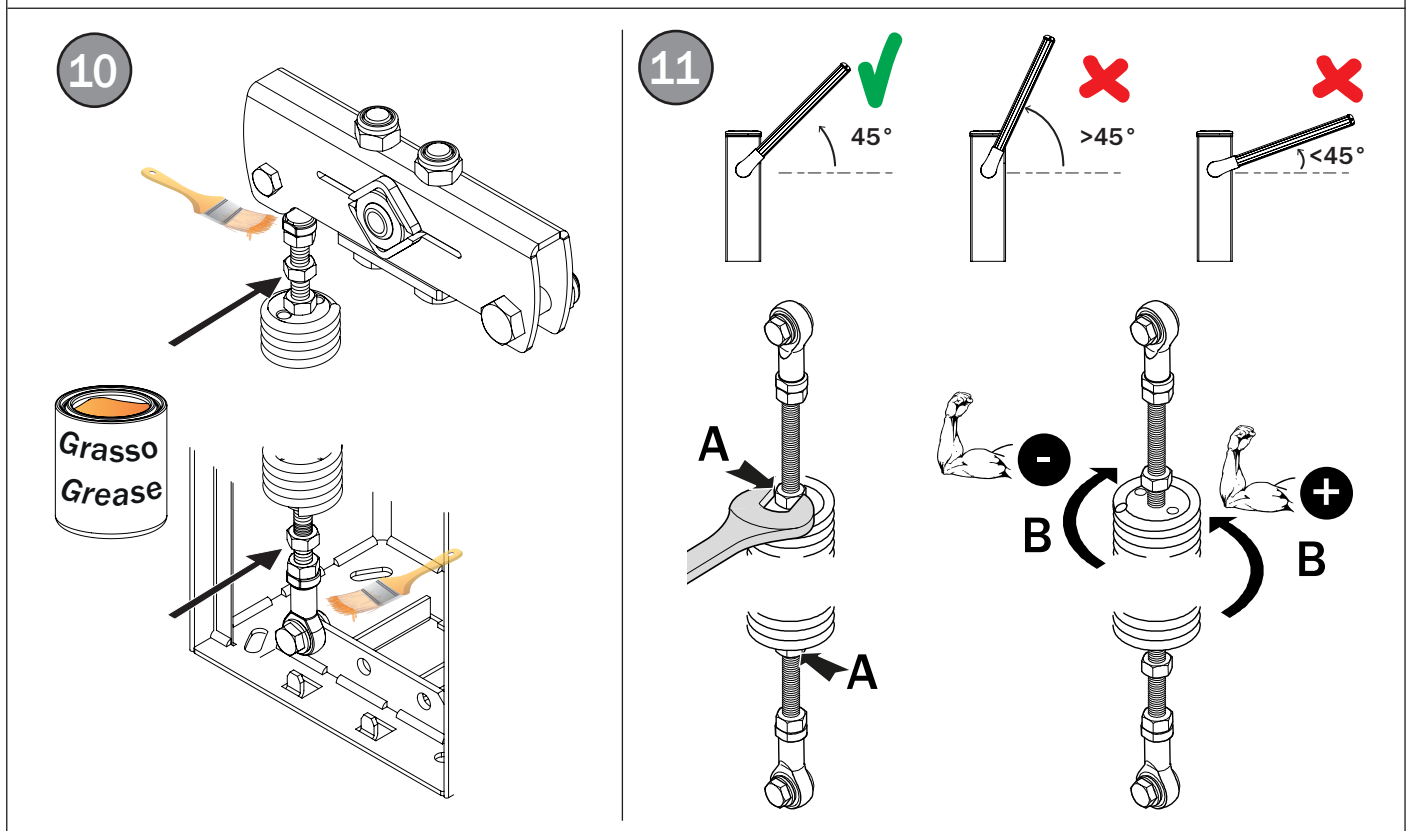
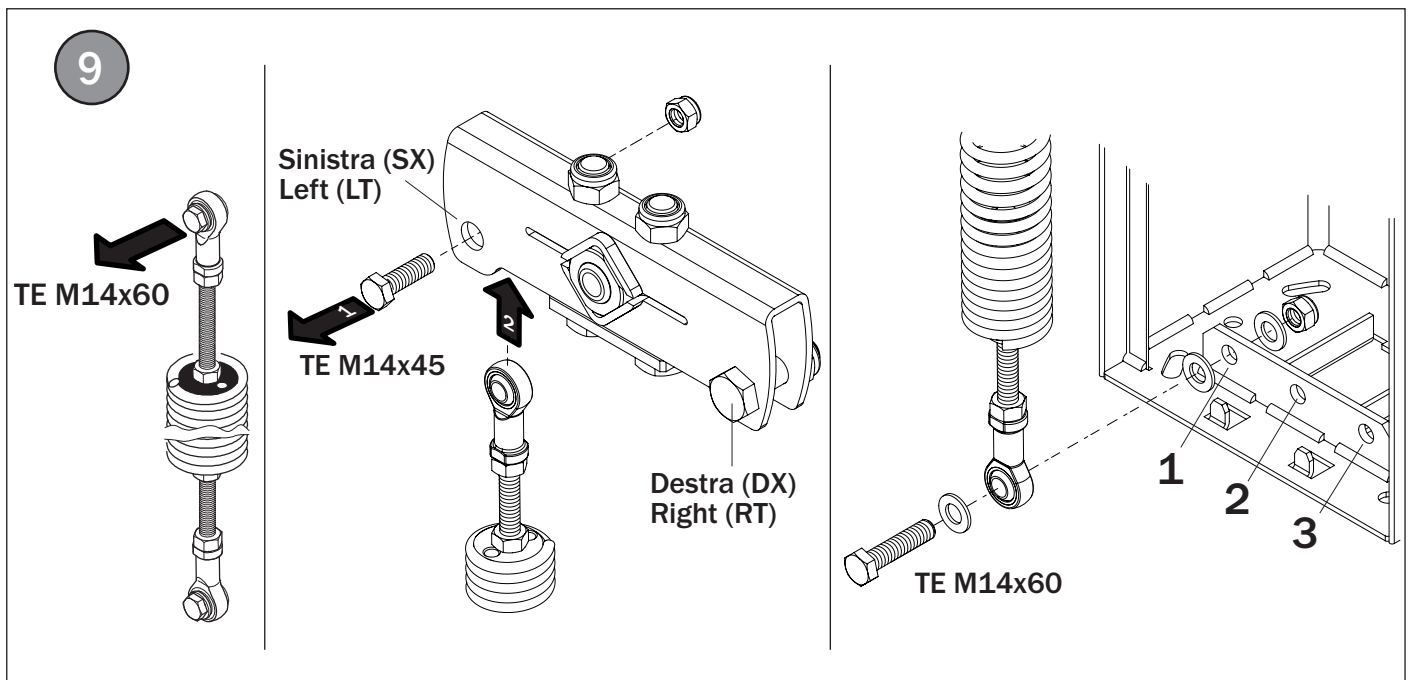







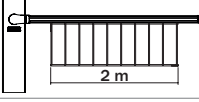
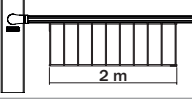
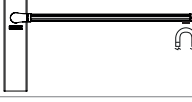
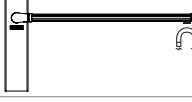

12 INSTALLING AND ADJUSTING THE SPRING

- Select the desired opening direction as indicated in paragraph 11.4.
- Unlock the barrier (see chapter 21) and move the boom into the completely open vertical position.
- Select the most suitable spring (see tables in paragraph 12.1).
- The springs are colour coded for identification. The coloured part of the spring must always be at the top:
 - green - Ø48 springs (SP/48/01);
 - blue - Ø61 springs (SP/61/01);
 - red - Ø72 springs (SP/72/01).
- Unscrew the upper screw TE M14x60 of the spring (viewed from the top coloured side).
- Unscrew the screw TE M14x45 from the linkage lever and fasten the spring with the same screw (fig. 9):
 - For barriers with left-side opening, use the SX1 or SX2 holes.
 - For barriers with right-side opening, use the DX2 or DX3 holes.
- Fasten the springs to the fixed structure (fig. 9), on the steel cross bar of the barrier, using the screws TE M14x60 included in the package.
- Lubricate the pivot points with lithium based grease (EP LITIO) (fig. 10). Available upon request, article **RS/GR1/100**: 100 g can of lithium grease.
- To adjust the spring tension, loosen the nuts **[A]** as indicated in fig. 10-11. Then turn the spring **[B]** clockwise to reduce the tension or anticlockwise to increase tension (fig. 11).
- Lift the boom manually to an angle of 45° and let go. If the boom rises, reduce the spring tension. If the boom drops, increase the spring tension.
- Once the spring tension is correct, tighten the nuts securely **[A]**.

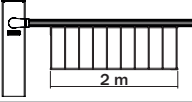
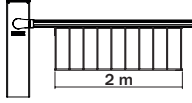
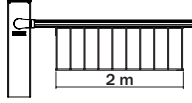
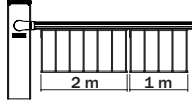
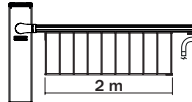
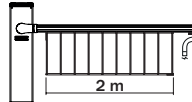
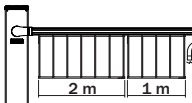

12.1 Spring selection

i The booms are understood as complete with shock-resistant rubber and LED strips.

		BA/68/3 (with boom from 2,2 to 2,80 m)	BA/68/3 (boom up to 3 m)	BA/68/4 (boom up to 4 m)
SP/48/01			NOT AVAILABLE	NOT AVAILABLE
SP/61/01		NOT AVAILABLE		
		NOT AVAILABLE		NOT AVAILABLE
				NOT AVAILABLE
		NOT AVAILABLE		
			NOT AVAILABLE	NOT AVAILABLE
SP/72/01		NOT AVAILABLE	NOT AVAILABLE	
		NOT AVAILABLE	NOT AVAILABLE	
		NOT AVAILABLE		
		NOT AVAILABLE	NOT AVAILABLE	
		NOT AVAILABLE		
		NOT AVAILABLE	NOT AVAILABLE	
		NOT AVAILABLE		
		NOT AVAILABLE		

* The adjustable fixed end rest with integrated magnet BAFS/05 must be used.

* Configuration only possible if the drop skirt is installed as close as possible to the cabinet.

* The fixed end rest must be used.

* The adjustable fixed end rest with integrated magnet BAFS/05 must be used.

* The adjustable fixed end rest with integrated magnet BAFS/05 must be used.

13 ADJUSTING THE MECHANICAL STOP

The figure shows the mechanical stop on a barrier installed on the **LEFT** hand side. For barriers installed on the **RIGHT**, perform the mirror images of the procedures illustrated.

- Unlock the barrier (see chapter 21).
- Set the completely open **[AP]** and completely closed **[CH]** positions by adjusting the relative mechanical stops.
- Lock the barrier (see chapter 21).

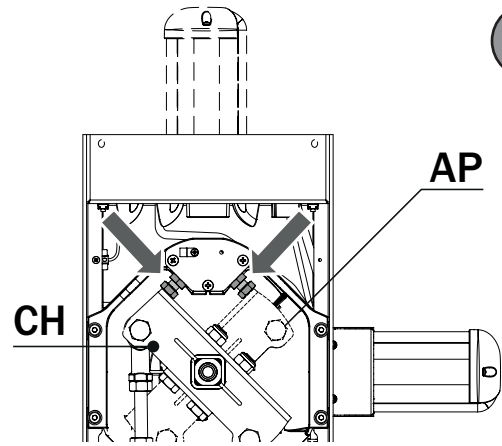

14 CONNECTING PHOTOCELLS

F4ES type photocells may be installed on both sides of the barrier at two different heights: (50 cm or 100 cm).

1. Disconnect the mains power (if applicable).
2. Switch the control unit switch to the **OFF** position (fig. 15).
3. Open the photocells, rest the base on the cabinet and use it as a drilling template.
4. Drill the barrier cabinet as shown in figure 13 and fasten the base of the photocells.
5. Route the connector cables upwards, taking care not to interfere with the movements of the automation system and through the cable conduit indicated in figure 14.
6. Connect the photocells to the terminals **COM-FT1/FT2** as indicated in the control unit installation manual.
7. Refer to the control unit manual for the photocell settings.
8. Set the switch to the **ON** position.
9. Reconnect to mains power.

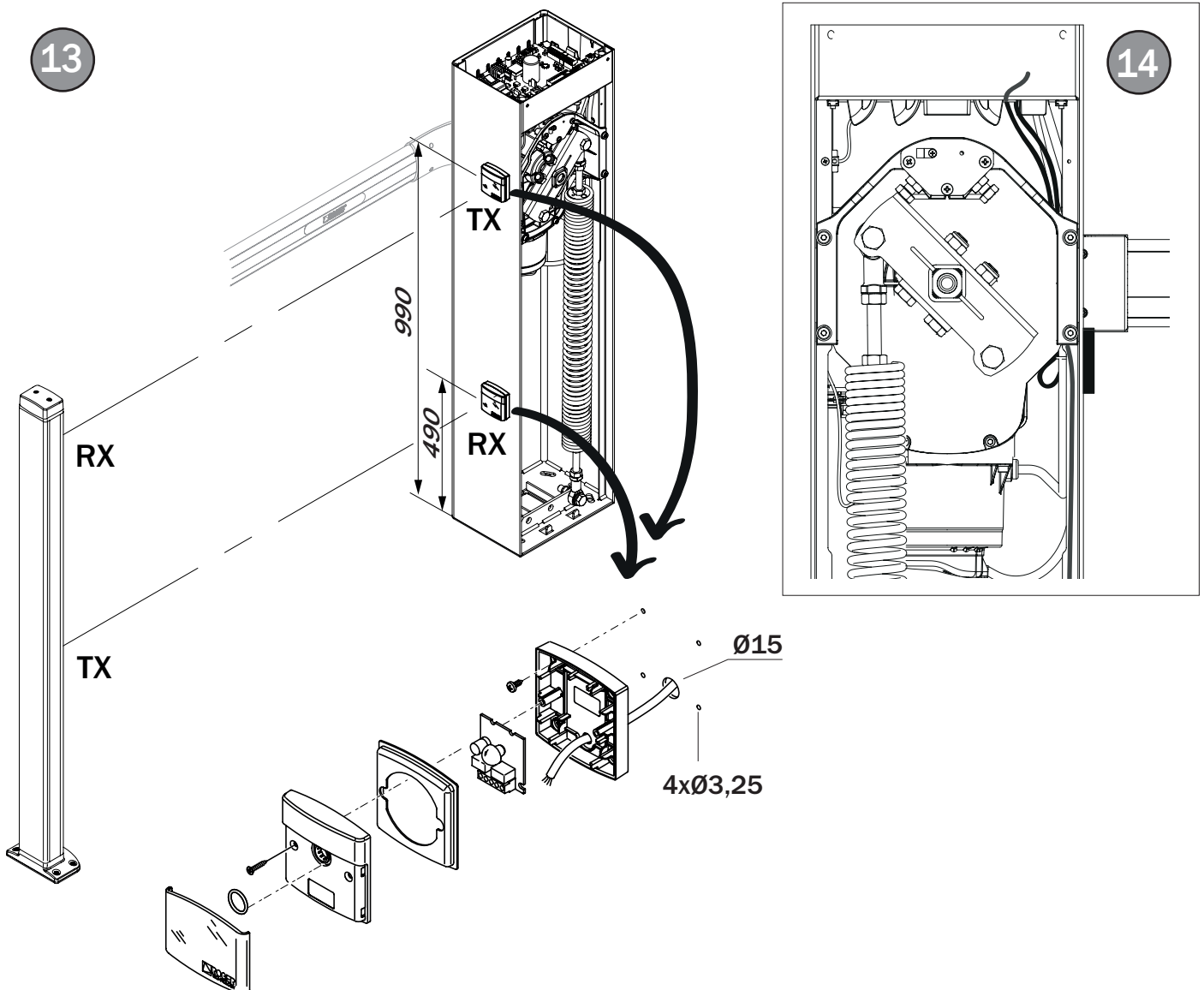

15 ELECTRICAL CONNECTIONS

All electrical connections must be made with the unit disconnected from mains power and, if applicable, battery power. See controller manual for instructions on making connections and programming.

Before connecting to electrical power, ensure that the mains power specifications on the identification plate match the mains power supply used.

A switch or an omnipolar cut-off switch with a contact opening of at least 3 mm must be installed on the mains power line.

Ensure that an adequate residual current circuit breaker and a suitable overcurrent cut-out are installed ahead of the electrical installation.

Use a 3x2.5 mm² double insulated cable for the mains power line.

Feed the cable on the left hand side of the barrier through the rubber cable grommet on the left hand side of the controller casing and connect it to the terminals L (brown), N (blue) and \ominus (yellow/green) inside the automation unit.

Fasten the power cable with the cable grips included.

At least 50 mm of the connector cable conduit must protrude from the holes in the base plate and into the automation unit.

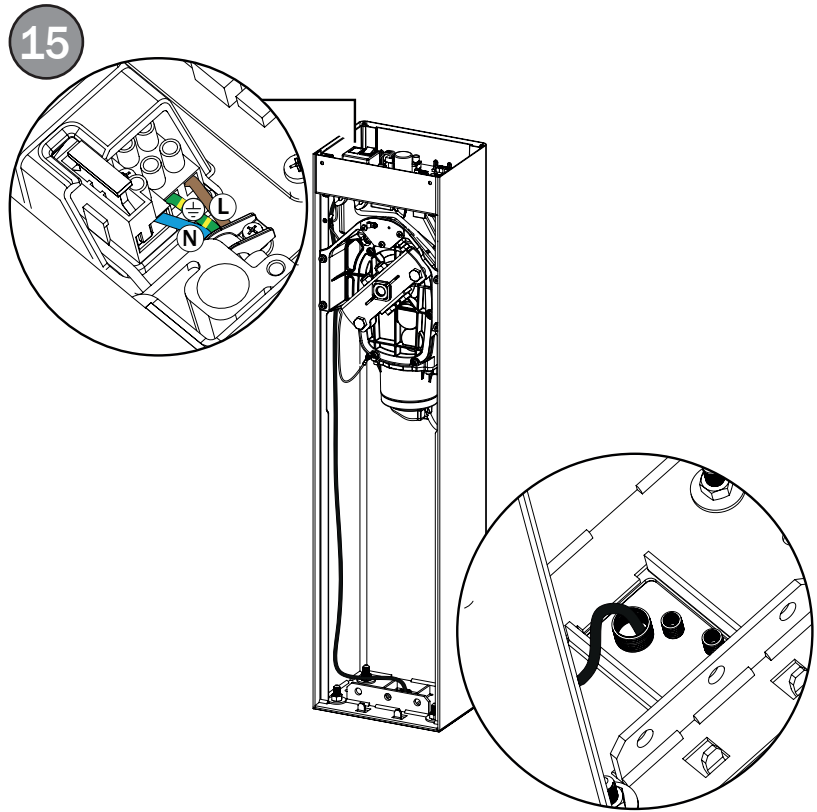

16 INSTALLING THE BATTERY KIT (OPTIONAL)

1. Disconnect the mains power.
2. Unscrew the screws and remove the head **[A]** (if applicable).
3. Lift the cable grommet **[B]** and disconnect the connector **[C]**.
4. Open the transparent control unit cover **[D]**.
5. Switch the control unit switch to the OFF position **[E]**.
6. Lift the control unit and insert the batteries in their housing **[F]**.
7. Connect the red, black and blue wires to the batteries (see detailed view)
8. Connect the batteries to the **+BATTERY** terminal (red wire) and **-BATTERY** terminal (black wire).
9. Insert the battery charge board BI/BCHP in the plug-in connector **[G]**.
10. Reposition the control unit.
11. Switch the control unit switch to the ON position **[E]**.
12. Reposition the transparent control unit cover **[D]**.
13. Reconnect the connector **[C]** and close the cable grommet **[B]**.
14. Close the head **[A]** and tighten the front screws.
15. Reconnect the mains power.

16

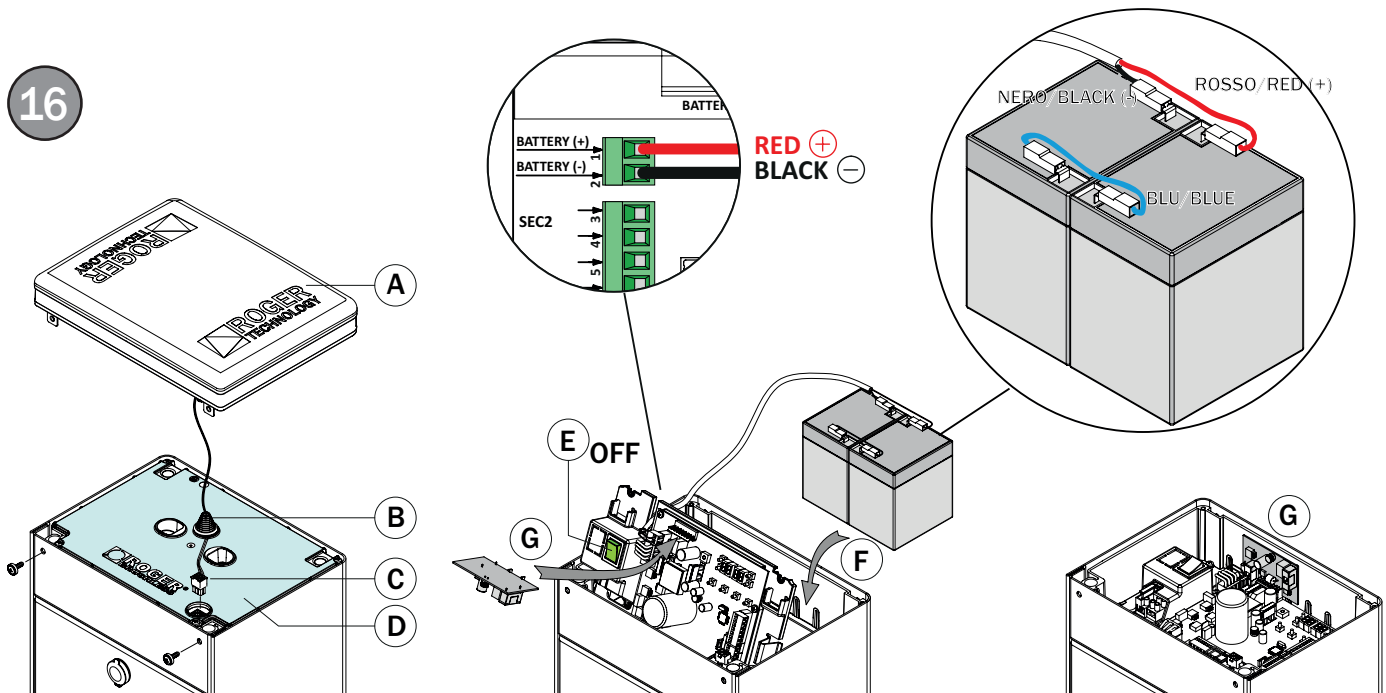

17 INSTALLING THE BI/BLED LED FLASHING LIGHT

The **BI/BLED** flashing lamp unit is factory supplied already pre-installed in the head **[A]**, packaged separately inside the BIONIK4 package.

1. Insert the connector **[B]** in the LIGHT terminal of the control unit.
2. Refer to the control unit manual for the flashing lamp unit settings.
3. Fasten the cable grommet **[C]**, making sure it is positioned correctly.
4. Position the head **[A]** on the barrier.
5. Tighten the fastening screws.

In case of replacement:

1. Disconnect the mains and battery power supplies (if applicable).
2. Unscrew the screws that fasten the head **[A]** to the barrier.
3. Lift the cable grommet **[C]**.
4. Disconnect the connector **[B]**.
5. Remove and overturn the head **[A]**.
6. Remove the **BI/BLED** flashing lamp unit **[D]** from the diffuser.
7. Insert the new LED circuit in the diffuser, paying attention to the installation direction (fig. 18).
8. Insert the connector **[B]** in the LIGHT terminal of the control unit.
9. Refer to the control unit manual for the flashing lamp unit settings.
10. Fasten the cable grommet **[C]**, making sure it is positioned correctly.
11. Reposition the head **[A]** on the barrier.
12. Tighten the fastening screws.
13. Reconnect the mains and battery power supplies (if applicable).

17

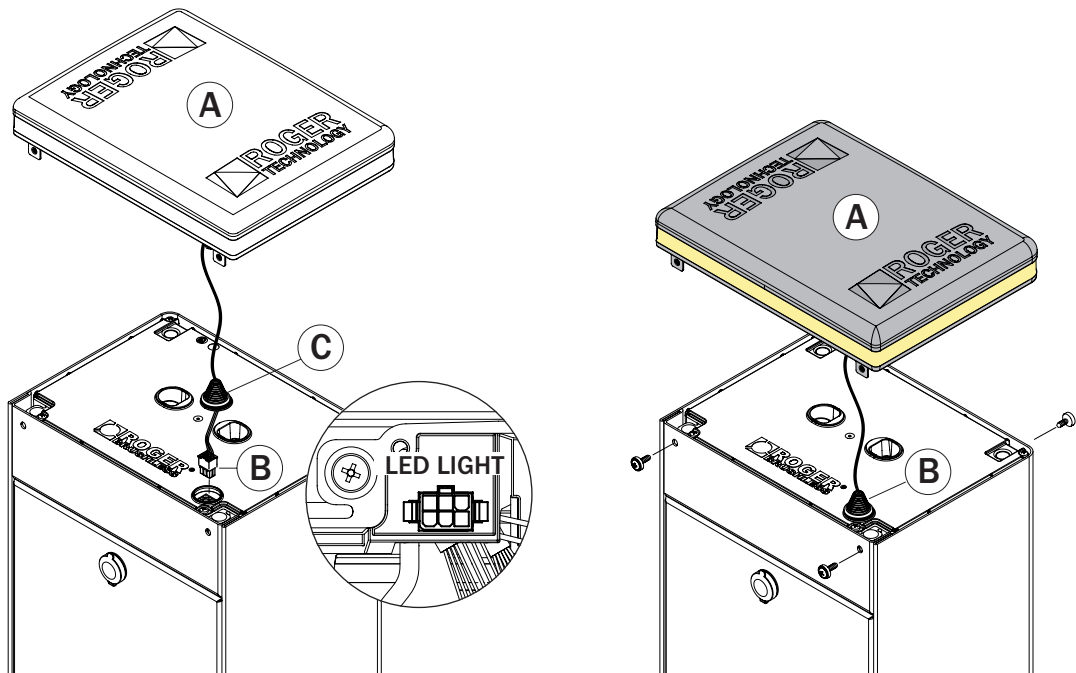

18

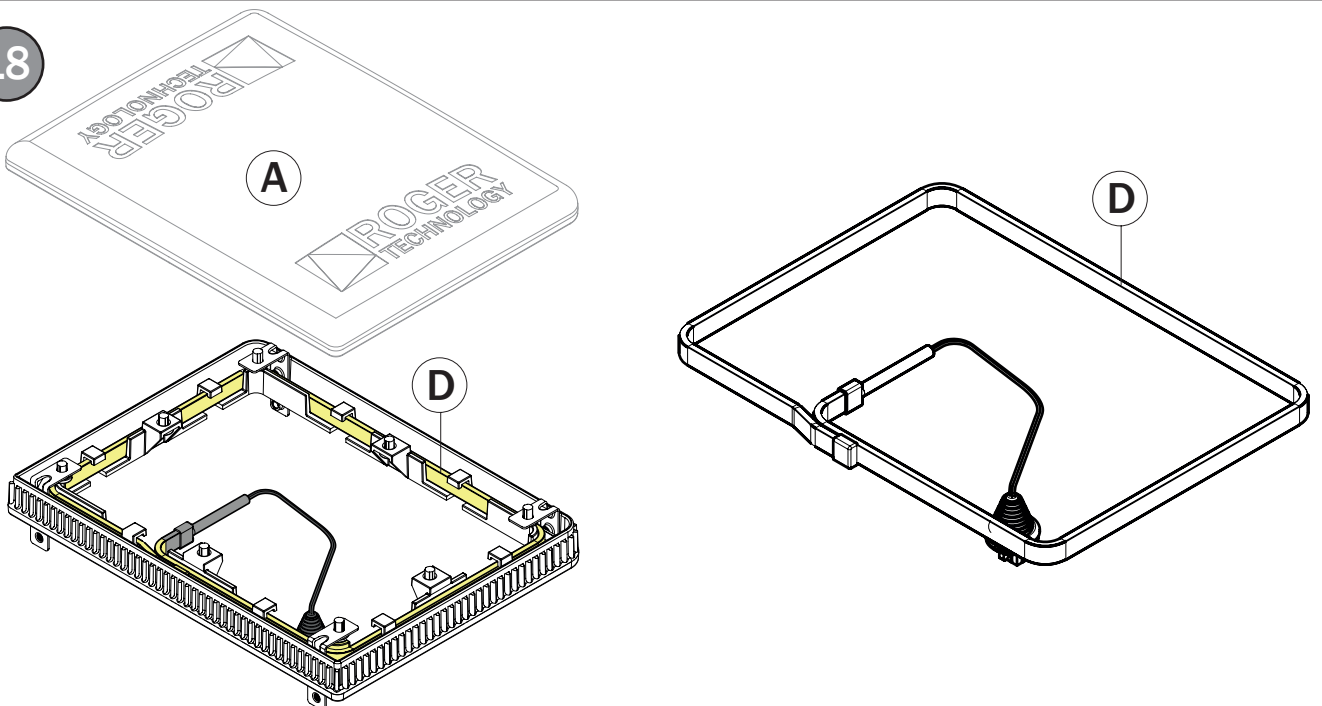

18 MAINTENANCE

N.B.: Only use original spare parts when repairing or replacing products. The installer must provide the user with complete instruction for using the motorised door or gate in automatic, manual and emergency modes, and must hand the operating instructions to the user of the installation upon completion. The installer must compile the maintenance log book, in which all scheduled and unscheduled maintenance operations performed must be indicated.

- The installation must be subject to regular maintenance. We recommend servicing at least once every 6 months.
- Disconnect from mains electricity and from battery power (if applicable) to avoid the risk of accident or injury.
- Check the tightness of all the fastener screws and nuts.
- Clean the photocell lenses with a cloth moistened slightly with water. Do not use solvents or other chemical products, as these may damage the electronic components.
- Clean and lubricate the pivot points with lithium based grease (EP LITIO).
- Check the electrical connections.
- Check that the manual lock release system works.
- Check that the boom is balanced correctly as indicated in chapter 12.
- Check that there are now plants within the radius of action of the boom which could interfere with the photocells or with the movements of the boom itself.

Reconnect to mains power.

- Check that the safety devices and all the control functions work correctly.
- Check that the obstacle detection function works correctly.
- Check that there is no risk of the boom accidentally lifting persons or objects.
- Check that the force limiting function prevent potentially dangerous situations in compliance with the standard EN 12445.

19 DISPOSAL



This product may only be uninstalled by qualified technical personnel, following suitable procedures for removing the product correctly and safely.

This product consists of numerous different materials.

Some of these materials may be recycled, while others must be disposed of correctly at the specific recycling or waste management facilities indicated by local legislation applicable for this category of product.

Do not dispose of this product as domestic refuse.

Observe local legislation for differentiated refuse collection, or hand the product over to the vendor when purchasing an equivalent new product.

Local legislation may envisage severe fines for the incorrect disposal of this product.

Warning! some parts of this product may contain substances that are harmful to the environment or dangerous and which may cause damage to the environment or health risks if disposed of incorrectly.

20 ADDITIONAL INFORMATION AND CONTACT

ROGER TECHNOLOGY is the exclusive proprietor holder of all rights regarding this publication.

ROGER TECHNOLOGY reserves the right to implement any modifications without prior notification. Copying, scanning or any alterations to this document are prohibited without express prior authorised from by ROGER TECHNOLOGY.

ROGER TECHNOLOGY CUSTOMER SERVICE:

business hours: Monday to Friday
08:00 to 12:00 - 13:30 to 17:30

Telephone no: +39 041 5937023

E-mail: support@rogertechnology.it

Skype: service_rogertechnology

21 RELEASE AND LOCK PROCEDURE

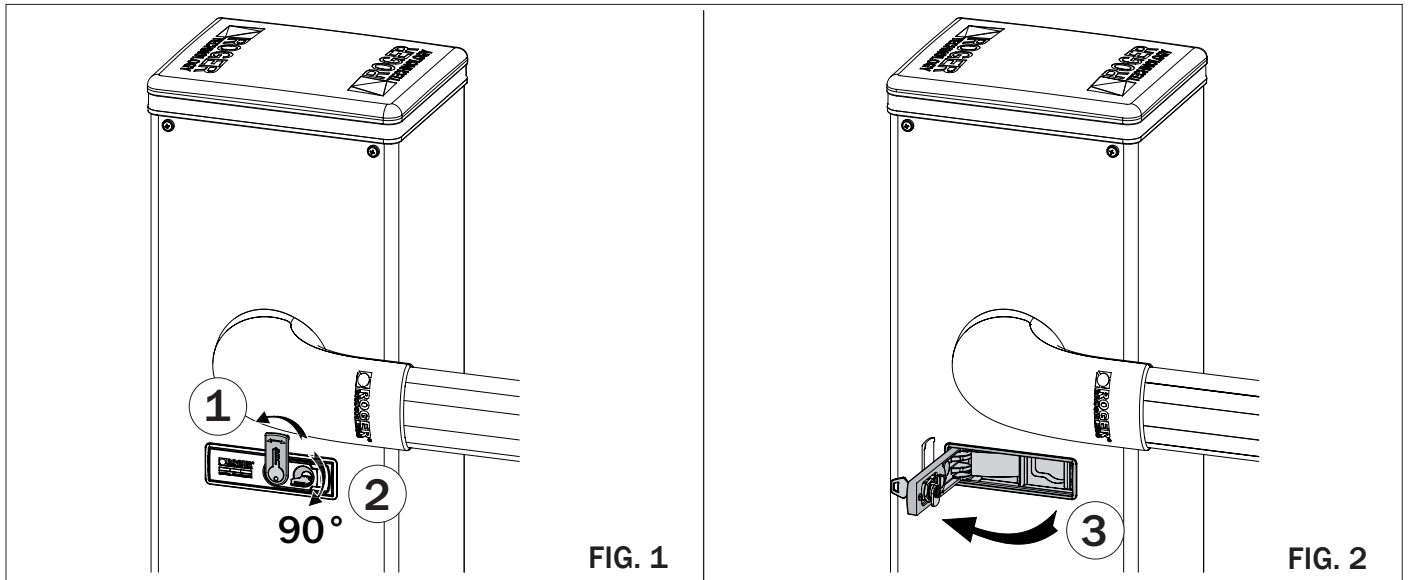

⚠ Whenever corrective actions are carried out, pay the utmost attention when releasing, locking or moving the internal mechanical parts. These operations could be hazardous for the installer.

Unlock the barrier in the event of a power outage or before performing scheduled maintenance or repairs. The unlock procedure must be performed with the boom in the closed position.

Ensure that there are no persons, objects or animals within the operating radius of the barrier when unlocking.

RELEASE AND MANUAL OPERATION

Open the lock cover as indicated in step 1.

Insert the key included into the lock and turn clockwise by 90°, as indicated in step 2.

Open the release cover completely (3).

Move the boom manually.

RESTORING AUTOMATIC OPERATION

To relock the barrier, close the release cover by turning the key 90° clockwise, paying attention to your fingers.

With the door closed, turn the key 90° anticlockwise.

Remove the key and close the lock cover.